



EMC TEST REPORT

ETSI EN 301 489-1 V2.1.1 (2017-02)

(Final Draft) ETSI EN 301 489-3 V2.1.1 (2017-03)

Product: LoRa RF Transceiver Module

Trade Mark: G-NiceRF

Model Name: LoRa 1276-C1-868

Serial Model: N/A

Report No.: SER171019767002E

Prepared for

NiceRF Wireless Technology LTD.

309-314, Bldg A, Hongdu business building, Xin'an street, Zone 43,
Baoan Dist, Shenzhen 518101, China

Prepared by

Shenzhen NTEK Testing Technology Co., Ltd.

1/F, Building E, Fenda Science Park, Sanwei Community, Xixiang Street
Bao'an District, Shenzhen 518126 P.R. China

Tel.: +86-755-6115 6588 Fax.: +86-755-6115 6599

Website: <http://www.ntek.org.cn>

Table of Contents	Page
1 . TEST SUMMARY	5
1.1 TEST FACILITY	6
1.2 MEASUREMENT UNCERTAINTY	6
2 . GENERAL INFORMATION	7
2.1 DESCRIPTION OF TEST MODES	8
2.2 DESCRIPTION OF TEST SETUP	9
2.3 DESCRIPTION TEST PERIPHERAL AND EUT PERIPHERAL	10
2.4 MEASUREMENT INSTRUMENTS LIST	11
3 . EMC EMISSION TEST	13
3.1 CONDUCTED EMISSION MEASUREMENT	13
3.1.1 POWER LINE CONDUCTED EMISSION	13
3.1.2 TEST PROCEDURE	14
3.1.3 TEST SETUP	14
3.1.4 EUT OPERATING CONDITIONS	14
3.1.5 TEST RESULTS	15
3.2 RADIATED EMISSION MEASUREMENT	16
3.2.1 LIMITS OF RADIATED EMISSION MEASUREMENT (Below 1000MHz)	16
3.2.2 LIMITS OF RADIATED EMISSION MEASUREMENT	16
3.2.3 TEST PROCEDURE	16
3.2.4 TEST SETUP	17
3.2.5 EUT OPERATING CONDITIONS	17
3.2.6 TEST RESULTS	18
3.2.7 TEST RESULTS(1000~6000MHz)	20
3.3 HARMONICS CURRENT	21
3.3.1 LIMITS OF HARMONICS CURRENT	21
3.3.1.1 TEST PROCEDURE	22
3.3.1.2 EUT OPERATING CONDITIONS	22
3.3.1.3 TEST SETUP	22
3.3.2 TEST RESULTS	23
3.4 VOLTAGE FLUCTUATION AND FLICKERS	24
3.4.1 LIMITS OF VOLTAGE FLUCTUATION AND FLICKERS	24
3.4.1.1 TEST PROCEDURE	24
3.4.1.2 EUT OPERATING CONDITIONS	24
3.4.1.3 TEST SETUP	24
3.4.2 TEST RESULTS	26
4 . EMC IMMUNITY TEST	27

Table of Contents	Page
4.1 STANDARD COMPLIANCE/SERVRITY LEVEL/CRITERIA	27
4.2 GENERAL PERFORMANCE CRITERIA	28
4.3 GENERAL PERFORMANCE CRITERIA TEST SETUP	28
4.4 ESD TESTING	29
4.4.1 TEST SPECIFICATION	29
4.4.2 TEST PROCEDURE	29
4.4.3 TEST SETUP	30
4.4.4 TEST RESULTS	31
4.4.1 PHOTO(S) SHOWN THE LOCATION(S) OF ESD EVALUATED	错误! 未定义书签。
4.5 RS TESTING	32
4.5.1 TEST SPECIFICATION	32
4.5.2 TEST PROCEDURE	32
4.5.3 TEST SETUP	33
4.5.4 TEST RESULTS	34
4.6 EFT/BURST TESTING	35
4.6.1 TEST SPECIFICATION	35
4.6.2 TEST PROCEDURE	35
4.6.3 TEST SETUP	36
4.6.4 TEST RESULTS	37
4.7 SURGE TESTING	38
4.7.1 TEST SPECIFICATION	38
4.7.2 TEST PROCEDURE	38
4.7.3 TEST SETUP	39
4.7.4 TEST RESULTS	40
4.8 INJECTION CURRENT TESTING	41
4.8.1 TEST SPECIFICATION	41
4.8.2 TEST PROCEDURE	41
4.8.3 TEST SETUP	42
4.8.4 TEST RESULTS	43
4.9 VOLTAGE INTERRUPTION/DIPS TESTING	44
4.9.1 TEST SPECIFICATION	44
4.9.2 TEST PROCEDURE	44
4.9.3 TEST SETUP	44
4.9.4 TEST RESULTS	45
5 . EUT TEST PHOTO	46

1. TEST SUMMARY

Test procedures according to the technical standards:
 ETSI EN 301 489-1 V2.1.1 (2017-02)
 (Final Draft) ETSI EN 301 489-3 V2.1.1 (2017-03)

EMC Emission				
Standard	Test Item	Limit	Judgment	Remark
EN 55032:2015	Conducted Emission	Class B	N/A	
	Radiated Emission	Class B	PASS	
EN61000-3-2:2014	Harmonic Current Emission	Class D NOTE (2)	N/A	
EN 61000-3-3:2013	Voltage Fluctuations & Flicker	-----	N/A	
EMC Immunity				
Section EN 55024:2010	Test Item	Performance Criteria	Judgment	Remark
EN 61000-4-2:2009	Electrostatic Discharge	B	PASS	
EN 61000-4-3:2006+A1:2008+A2: 2010	RF electromagnetic field	A	PASS	
EN 61000-4-4:2012	Fast transients	B	N/A	
EN 61000-4-5:2006	Surges	B	N/A	
EN 61000-4-6:2007	Injected Current	A	N/A	
EN 61000-4-8:2009	Power Frequency Magnetic Field	A	N/A	
EN 61000-4-11:2004	Volt. Interruptions Volt. Dips	B / C / C NOTE (3)	N/A	

NOTE:

- (1) "N/A" denotes test is not applicable in this Test Report
- (2) The power consumption of EUT is less than 75W and no Limits apply.
- (3) Voltage dip: 100% reduction – Performance Criteria **B**
 Voltage dip: 30% reduction – Performance Criteria **C**
 Voltage Interruption: 100% Interruption – Performance Criteria **C**
- (4) For client's request and manual description, the test will not be executed.

1.1 TEST FACILITY

Shenzhen NTEK Testing Technology Co., Ltd

Add. : 1/F, Building E, Fenda Science Park, Sanwei Community, Xixiang Street, Bao'an District, Shenzhen P.R. China.

FCC FRN Registration Number: 463705; IC Registration Number:9270A-1

CNAS Registration No.:L5516

1.2 MEASUREMENT UNCERTAINTY

The reported uncertainty of measurement $y \pm U$, where expanded uncertainty U is based on a standard uncertainty multiplied by a coverage factor of $k=2$, providing a level of confidence of approximately **95 %**.

A. Conducted Measurement :

Test Site	Method	Measurement Frequency Range	U,(dB)	NOTE
NTEKC01	ANSI	150 KHz ~ 30MHz	3.2	

B. Radiated Measurement :

Test Site	Method	Measurement Frequency Range	U,(dB)	NOTE
NTEKA01	ANSI	30MHz ~ 1000MHz	4.7	
		1GHz ~6GHz	5.0	

2. GENERAL INFORMATION

2.1 GENERAL DESCRIPTION OF EUT

Equipment	LoRa RF Transceiver Module
Trade Mark	G-NiceRF
Model Name	LoRa 1276-C1-868
Serial Model	N/A
Model Difference	N/A
Frequency Bands:	863 MHz to 870 MHz 870 MHz to 875.8 MHz
Receiver category	2
Power Rating	DC 3.3V
AC Supply	N/A
Battery	N/A
Connecting I/O Port(s)	Please refer to the User's Manual
Hardware Version	V1.0
Software Version	V1.0

Note:

1. For a more detailed features description, please refer to the manufacturer's specifications or the User's Manual.

2.1 DESCRIPTION OF TEST MODES

To investigate the maximum EMI emission characteristics generated from EUT, the test system was pre-scanning tested based on the consideration of following EUT operation mode or test configuration mode which possibly have effect on EMI emission level. Each of these EUT operation mode(s) or test configuration mode(s) mentioned above was evaluated respectively.

For Conducted Test	
Final Test Mode	Description
Mode1	Wireless

For Radiated Test	
Final Test Mode	Description
Mode1	Wireless

For Conducted Test	
Final Test Mode	Description
Mode1	Wireless

For EMS Test	
Final Test Mode	Description
Mode1	Wireless

NOTE: The test modes were carried out for all operation modes. The final test mode of the EUT was the worst test mode for EMI, and its test data was showed.

2.2 DESCRIPTION OF TEST SETUP

RE

E-1-1
EUT

2.3 DESCRIPTION TEST PERIPHERAL AND EUT PERIPHERAL

The EUT has been tested as an independent unit together with other necessary accessories or support units. The following support units or accessories were used to form a representative test configuration during the tests.

Item	Equipment	Mfr/Brand	Model/Type No.	Series No.	Note
E-1-1	LoRa RF Transceiver Module	N/A	LoRa 1276-C1-868	N/A	TX

Item	Type	Shielded Type	Ferrite Core	Length	Note

Note:

- (1) The support equipment was authorized by Declaration of Confirmation.
- (2) For detachable type I/O cable should be specified the length in cm in 『Length』 column.
- (3) “YES” is means “shielded” “with core”; “NO” is means “unshielded” “without core”.

2.4 MEASUREMENT INSTRUMENTS LIST

2.4.1 CONDUCTED TEST SITE

Item	Kind of Equipment	Manufacturer	Type No.	Serial No.	Last calibration	Calibrated until	Calibration period
1	LISN	R&S	ENV216	101313	Apr. 19, 2017	Apr. 18, 2018	1 year
2	LISN	SCHWARZBECK	NNLK 8129	8129245	Jun. 06, 2017	Jun. 05, 2018	1 year
3	Pulse Limiter	SCHWARZBECK	VTSD 9561F	9716	Jun. 06, 2017	Jun. 05, 2018	1 year
4	50Ω Switch	ANRITSU CORP	MP59B	6200983704	Jul. 06, 2017	Jul. 05, 2018	1 year
5	Test Cable	N/A	C01	N/A	Apr. 21, 2017	Apr. 20, 2020	3 year
6	Test Cable	N/A	C02	N/A	Apr. 21, 2017	Apr. 20, 2020	3 year
7	Test Cable	N/A	C03	N/A	Apr. 21, 2017	Apr. 20, 2020	3 year
8	EMI Test Receiver	R&S	ESCI	101160	Jul. 06, 2017	Jul. 05, 2018	1 year

2.4.2 RADIATED TEST SITE

Item	Kind of Equipment	Manufacturer	Type No.	Serial No.	Last calibration	Calibrated until	Calibration period
1	Bilog Antenna	TESEQ	CBL6111D	31216	Apr. 09, 2017	Apr. 08, 2018	1 year
2	Test Cable	N/A	R-01	N/A	Apr. 21, 2017	Apr. 20, 2020	1 year
3	Test Cable	N/A	R-02	N/A	Apr. 21, 2017	Apr. 20, 2020	1 year
4	EMI Test Receiver	R&S	ESCI-7	101318	Jul. 06, 2017	Jul. 05, 2018	1 year
5	Antenna Mast	EM	SC100_1	N/A	N/A	N/A	N/A
6	Turn Table	EM	SC100	060531	N/A	N/A	N/A
7	50Ω Switch	Anritsu Corp	MP59B	6200983705	Jul. 06, 2017	Jul. 05, 2018	1 year
8	Spectrum Analyzer	Aglient	E4407B	MY45108040	Jul. 06, 2017	Jul. 05, 2018	1 year
9	Horn Antenna	EM	EM-AH-10180	2011071402	Apr. 09, 2017	Apr. 08, 2018	1 year
10	Amplifier	EM	EM-30180	060538	Aug. 09, 2017	Aug. 08, 2018	1 year

2.4.3 HARMONICS AND FLICK

Item	Kind of Equipment	Manufacturer	Type No.	Serial No.	Last calibration	Calibrated until	Calibration period
1	Harmonic & Flicker	EM TEST	DPA500	0303-04	Jul. 06, 2017	Jul. 05, 2018	1 year
2	AC Power Source	EM TEST	ACS500	0203-01	Jul. 06, 2017	Jul. 05, 2018	1 year

2.4.4 ESD

Item	Kind of Equipment	Manufacturer	Type No.	Serial No.	Last calibration	Calibrated until	Calibration period
1	ESD TEST GENERATOR	SCHAFFNER	NSG438	859	Jul. 06, 2017	Jul. 05, 2018	1 year

2.4.5 RS

Item	Kind of Equipment	Manufacturer	Type No.	Serial No.	Last calibration	Calibrated until	Calibration period
1	Signal Generator	R&S	SMT 06	832080/007	Jul. 06, 2017	Jul. 05, 2018	1 year
2	Log-Bicon Antenna	Schwarzbeck	VULB9161	4022	Aug. 15, 2017	Aug. 14, 2018	1 year
3	Power Amplifier	AR	150W1000M1	320946	Sep. 23, 2017	Sep. 22, 2018	1 year
4	Microwave Horn Antenna	AR	AT4002A	321467	Jul. 06, 2017	Jul. 05, 2018	1 year
5	Power Amplifier	AR	25S1G4A	308598	Sep. 23, 2017	Sep. 22, 2018	1 year

2.4.6 SURGE, EFT/BURST, VOLTAGE INTERRUPTION/DIPS

Item	Kind of Equipment	Manufacturer	Type No.	Serial No.	Last calibration	Calibrated until	Calibration period
1	Surge Generator	EVERFINE	EMS61000-5A	1101002	Jul. 06, 2017	Jul. 05, 2018	1 year
2	DIPS Generator	EVERFINE	EMS61000-11 K	1011002	Jul. 06, 2017	Jul. 05, 2018	1 year
3	EFT/B Generator	EVERFINE	EMS61000-4A-V2	1012005	Jul. 06, 2017	Jul. 05, 2018	1 year

2.4.7 INJECTION CURRENT

Item	Kind of Equipment	Manufacturer	Type No.	Serial No.	Last calibration	Calibrated until	Calibration period
1	Signal Generator	IFR	2023A	202301/368	Mar. 23, 2017	Mar. 22, 2018	1 year
2	Power Amplifier	AR	75A250AM1	0320709	Sep. 23, 2017	Sep. 22, 2018	1 year
3	CDN	FCC	FCC-801-M2	06043	Jun. 02, 2017	Jun. 01, 2018	1 year
4	EM Clamp	FCC	F-203I-23MM	504	Jun. 09, 2017	Jun. 08, 2018	1 year

3. EMC EMISSION TEST

3.1 CONDUCTED EMISSION MEASUREMENT

3.1.1 POWER LINE CONDUCTED EMISSION (Frequency Range 150KHz-30MHz)

FREQUENCY (MHz)	Class A (dBuV)		Class B (dBuV)	
	Quasi-peak	Average	Quasi-peak	Average
0.15 -0.5	79.00	66.00	66 - 56 *	56 - 46 *
0.50 -5.0	73.00	60.00	56.00	46.00
5.0 -30.0	73.00	60.00	60.00	50.00

Note:

- (1) The tighter limit applies at the band edges.
- (2) The limit of " * " marked band means the limitation decreases linearly with the logarithm of the frequency in the range.

The following table is the setting of the receiver

Receiver Parameters	Setting
Attenuation	10 dB
Start Frequency	0.15 MHz
Stop Frequency	30 MHz
IF Bandwidth	9 kHz

3.1.2 TEST PROCEDURE

- The EUT was placed 0.8 meters from the horizontal ground plane with EUT being connected to the power mains through a line impedance stabilization network (LISN). All other support equipments powered from additional LISN(s). The LISN provide 50 Ohm/ 50uH of coupling impedance for the measuring instrument.
- Interconnecting cables that hang closer than 40 cm to the ground plane shall be folded back and forth in the center forming a bundle 30 to 40 cm long.
- I/O cables that are not connected to a peripheral shall be bundled in the center. The end of the cable may be terminated, if required, using the correct terminating impedance. The overall length shall not exceed 1 m.
- LISN at least 80 cm from nearest part of EUT chassis.
- For the actual test configuration, please refer to the related Item –EUT Test Photos.

3.1.3 TEST SETUP

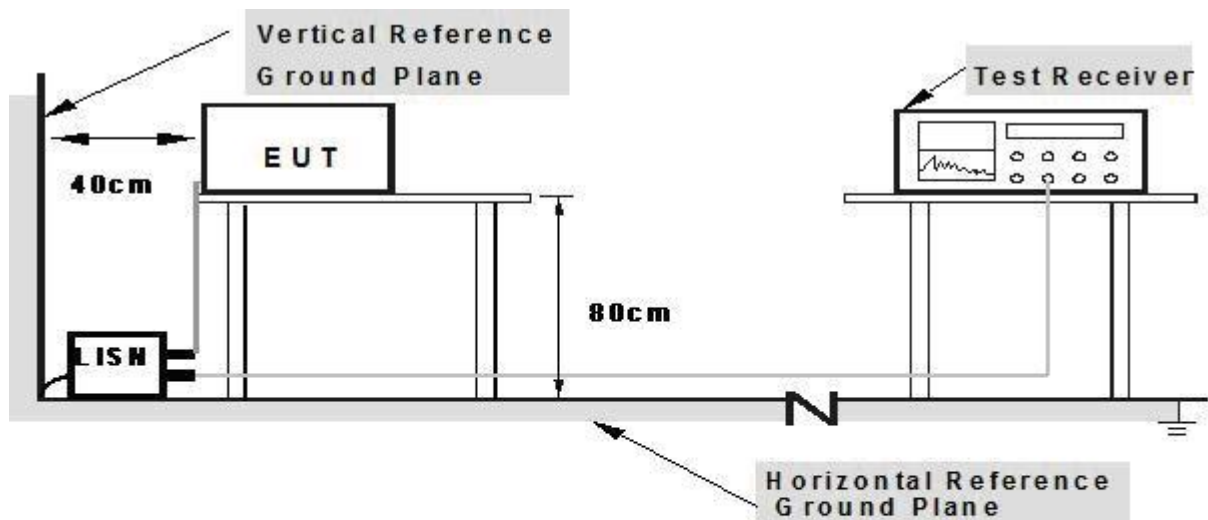

Note: 1. Support units were connected to second LISN.

2. Both of LISNs (AMN) are 80 cm from EUT and at least 80 cm from other units and other metal planes

3.1.4 EUT OPERATING CONDITIONS

The EUT tested system was configured as the statements of 2.3 Unless otherwise a special operating condition is specified in the follows during the testing.

3.1.5 TEST RESULTS

EUT:	LoRa RF Transceiver Module	Model Name:	LoRa 1276-C1-868
Temperature:	26 °C	Relative Humidity:	54%
Pressure:	1010 hPa	Polarization :	N/A
Test Voltage:	N/A	Test Mode:	N/A

3.2 RADIATED EMISSION MEASUREMENT

3.2.1 LIMITS OF RADIATED EMISSION MEASUREMENT (Below 1000MHz)

FREQUENCY (MHz)	Class A		Class B	
	At 10m	At 3m	At 10m	At 3m
	dBuV/m	dBuV/m	dBuV/m	dBuV/m
30 – 230	40	50	30	40
230 – 1000	47	57	37	47

3.2.2 LIMITS OF RADIATED EMISSION MEASUREMENT (Above 1000MHz)

FREQUENCY (MHz)	Class A (at 3m) dBuV/m		Class B (at 3m) dBuV/m	
	Peak	Avg	Peak	Avg
1000-3000	76	56	70	50
3000-6000	80	60	74	54

Notes:

- (1) The limit for radiated test was performed according to as following:
EN 55032.
- (2) The tighter limit applies at the band edges.
- (3) Emission level (dBuV/m)=20log Emission level (uV/m).

3.2.3 TEST PROCEDURE

- a. The measuring distance of at 3 m shall be used for measurements at frequency up to 1GHz. For frequencies above 1GHz, any suitable measuring distance may be used.
- b. The EUT was placed on the top of a rotating table 0.8 meters above the ground at a 10 meter open area test site. The table was rotated 360 degrees to determine the position of the highest radiation.
- c. The height of the equipment or of the substitution antenna shall be 0.8 m; the height of the test antenna shall vary between 1 m to 4 m. Both horizontal and vertical polarizations of the antenna are set to make the measurement.
- d. The initial step in collecting conducted emission data is a spectrum analyzer peak detector mode pre-scanning the measurement frequency range. Significant peaks are then marked and then Quasi Peak detector mode re-measured, above 1G Average detector mode will be instead.
- e. If the Peak Mode measured value compliance with and lower than Quasi Peak Mode Limit, the EUT shall be deemed to meet QP(AV) Limits and then no additional QP Mode measurement performed.
- f. For the actual test configuration, please refer to the related Item –EUT Test Photos.

3.2.4 TEST SETUP

(A) Radiated Emission Test Set-Up Frequency Below 1 GHz

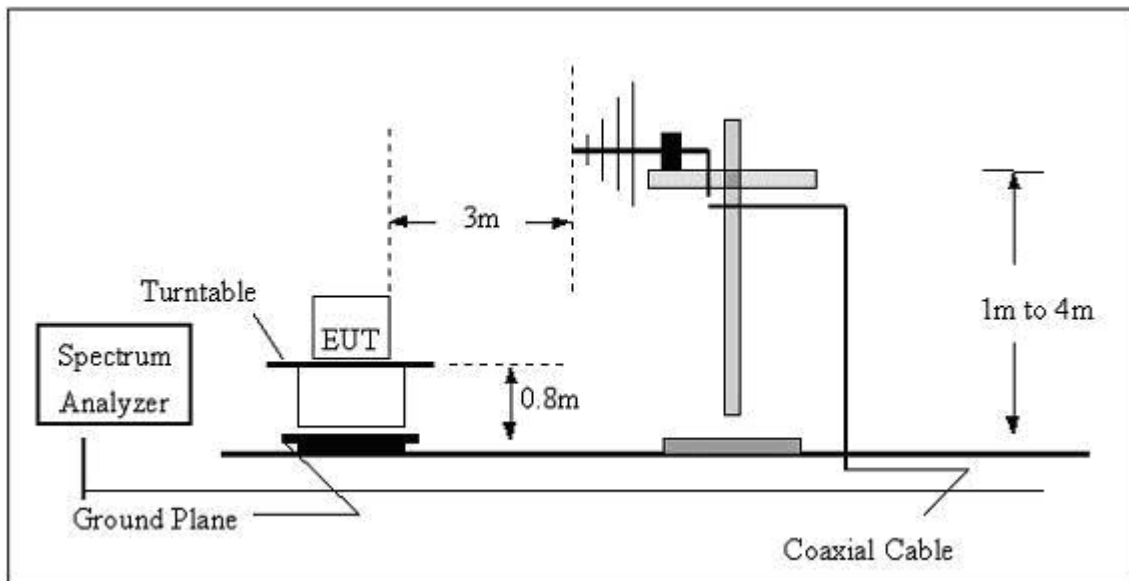

(B) Radiated Emission Test Set-Up Frequency Above 1GHz

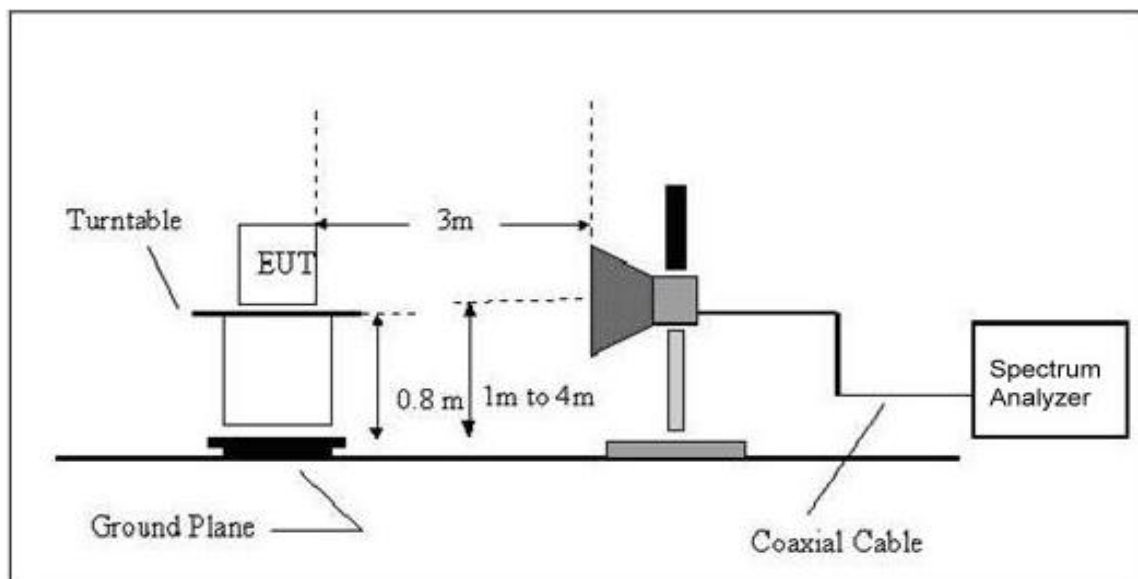

3.2.5 EUT OPERATING CONDITIONS

The EUT tested system was configured as the statements of **2.3** Unless otherwise a special operating condition is specified in the follows during the testing.

3.2.6 TEST RESULTS

EUT:	LoRa RF Transceiver Module	Model Name:	LoRa 1276-C1-868
Temperature:	25 °C	Relative Humidity:	55%
Pressure:	1010 hPa	Polarization :	Horizontal
Test Voltage:	DC3.3V	Test Mode:	Mode1

Frequency (MHz)	Meter Reading (dBμV)	Factor (dB)	Emission Level (dBμV/m)	Limits (dBμV/m)	Margin (dB)	Remark
30.7454	4.67	20.89	25.56	40	-14.44	QP
36.6375	5.63	18.15	23.78	40	-16.22	QP
44.2751	6.55	14.2	20.75	40	-19.25	QP
60.7043	7.12	10.64	17.76	40	-22.24	QP
420.5803	4.38	16.74	21.12	47	-25.88	QP
916.0687	7.22	25.09	32.31	47	-14.69	QP

Remark:

1. Factor = Antenna Factor + Cable Loss – Pre-amplifier.

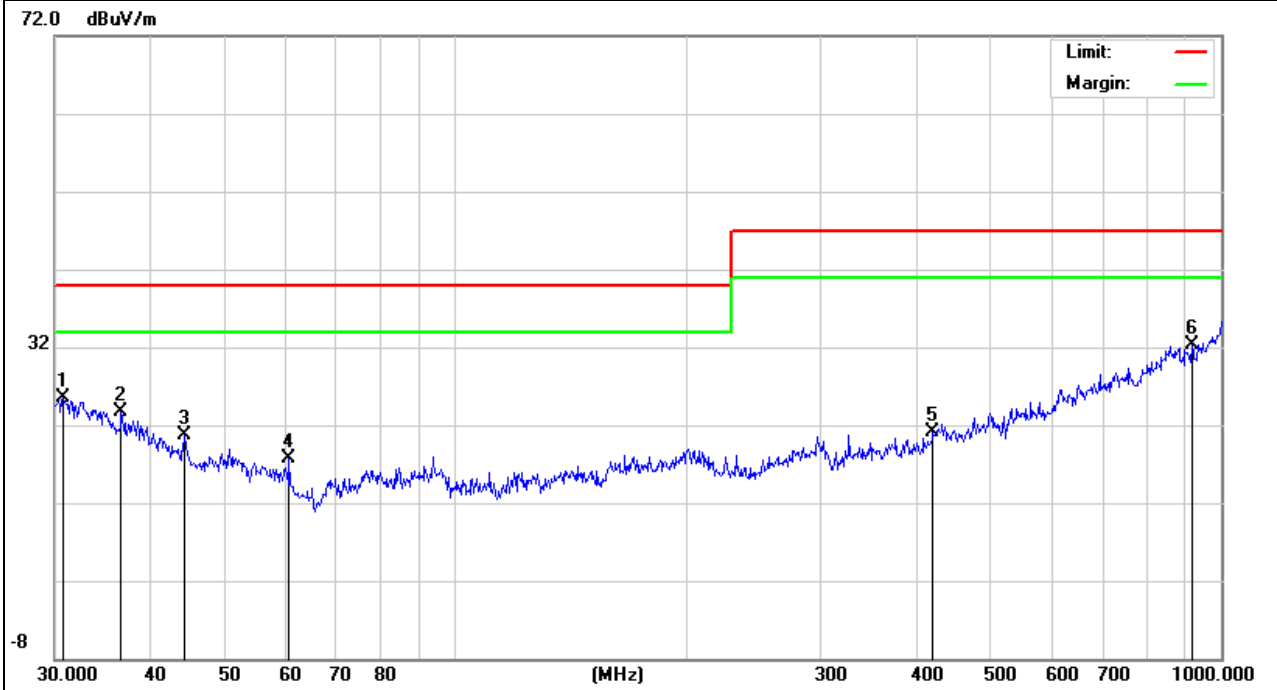

EUT:	LoRa RF Transceiver Module	Model Name:	LoRa 1276-C1-868
Temperature:	25 °C	Relative Humidity:	55%
Pressure:	1010 hPa	Polarization :	Vertical
Test Voltage:	DC3.3V	Test Mode:	Mode1

Frequency (MHz)	Meter Reading (dBμV)	Factor (dB)	Emission Level (dBμV/m)	Limits (dBμV/m)	Margin (dB)	Remark
32.634	7.08	20.04	27.12	40	-12.88	QP
48.6719	5.83	13.37	19.2	40	-20.8	QP
72.5916	7.69	10.67	18.36	40	-21.64	QP
93.7685	5.79	12.03	17.82	40	-22.18	QP
208.5801	5.96	13.45	19.41	40	-20.59	QP
329.039	12.53	13.84	26.37	47	-20.63	QP

Remark:

1. Factor = Antenna Factor + Cable Loss – Pre-amplifier.

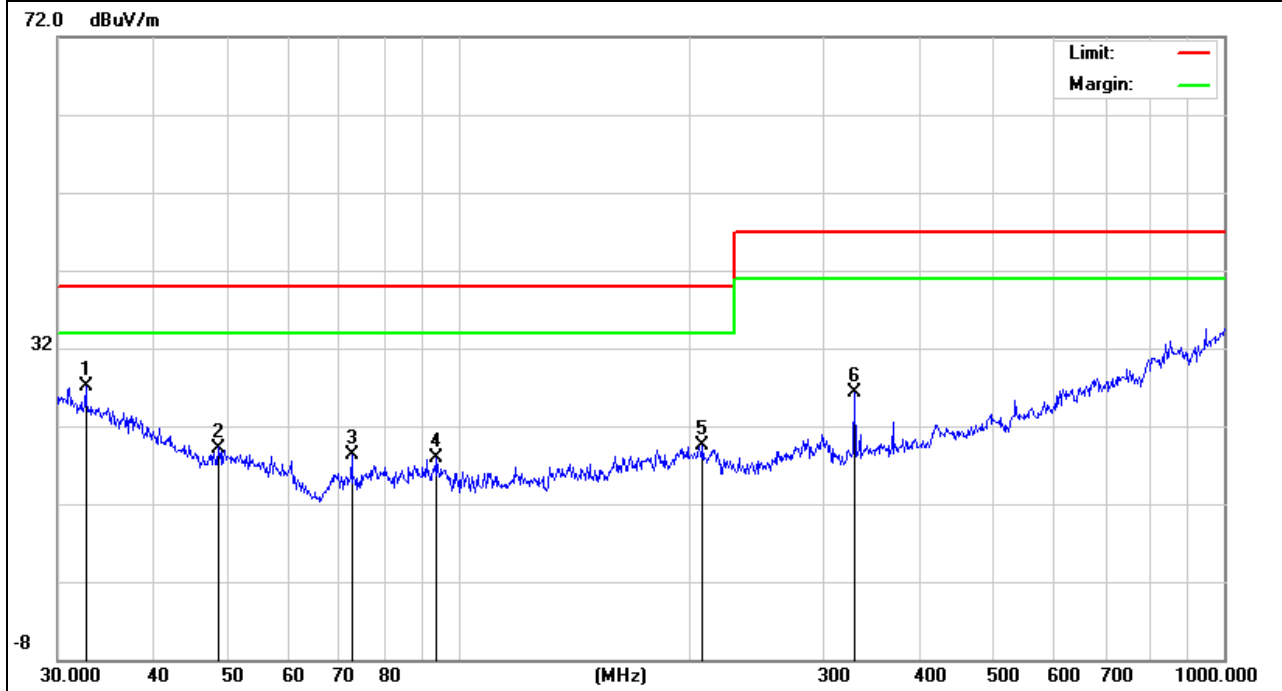

3.2.7 TEST RESULTS(1000~6000MHz)

EUT:	LoRa RF Transceiver Module	Model Name:	LoRa 1276-C1-868
Temperature:	24 °C	Relative Humidity:	54%
Test Power:	DC3.3V	Test Mode:	Mode1

Polar (H/V)	Frequency	Meter Reading	Factor	Emission Level	Limits	Margin	Remark
	(MHz)	(dBμV)	(dB)	(dBμV/m)	(dBμV/m)	(dB)	
V	2414.629	42.26	-9.52	32.74	70	-37.26	peak
V	2414.629	26.38	-9.52	16.86	50	-33.14	AVG
V	3639.545	41.6	-4.27	37.33	74	-36.67	peak
V	3639.545	25.56	-4.27	21.29	54	-32.71	AVG
H	2342.189	42.78	-9.82	32.96	70	-37.04	peak
H	2342.189	26.18	-9.82	16.36	50	-33.64	AVG
H	3973.53	41.21	-2.74	38.47	74	-35.53	peak
H	3973.53	26.31	-2.74	23.57	54	-30.43	AVG

Remark:

Absolute Level= ReadingLevel+ Factor, Margin= Absolute Level - Limit

3.3 HARMONICS CURRENT

3.3.1 LIMITS OF HARMONICS CURRENT

Table 1 – Limits for Class A equipment

Harmonic order (n)	Maximum permissible harmonic current (A)
Odd harmonics	
3	2.3
5	1.14
7	0.77
9	0.4
11	0.33
13	0.21
$15 \leq n \leq 39$	$0.15 * (15/n)$
Even harmonics	
2	1.08
4	0.43
6	0.30
$8 \leq n \leq 40$	$0.23 * (8/n)$

Note: Reference standard of the table above: EN61000-3-2.

3.3.1.1 TEST PROCEDURE

a. The EUT was placed on the top of a wooden table 0.8 meters above the ground and operated to produce the maximum harmonic components under normal operating conditions.

b. The classification of EUT is according to section 5 of EN 61000-3-2. The EUT is classified as follows:

Class A: Balanced three-phase equipment, Household appliances excluding equipment as Class D, Tools excluding portable tools, Dimmers for incandescent lamps, audio equipment, equipment not specified in one of the three other classes.

Class B: Portable tools. Portable tools.; Arc welding equipment which is not professional equipment.

Class C: Lighting equipment.

Class D: Equipment having a specified power less than or equal to 600W of the following types: Personal computers and personal computer monitors and television receivers.

c. The correspondent test program of test instrument to measure the current harmonics emanated from EUT is chosen. The measure time shall be not less than the time necessary for the EUT to be exercised.

3.3.1.2 EUT OPERATING CONDITIONS

The EUT tested system was configured as the statements of **2.3** Unless otherwise a special operating condition is specified in the follows during the testing.

3.3.1.3 TEST SETUP

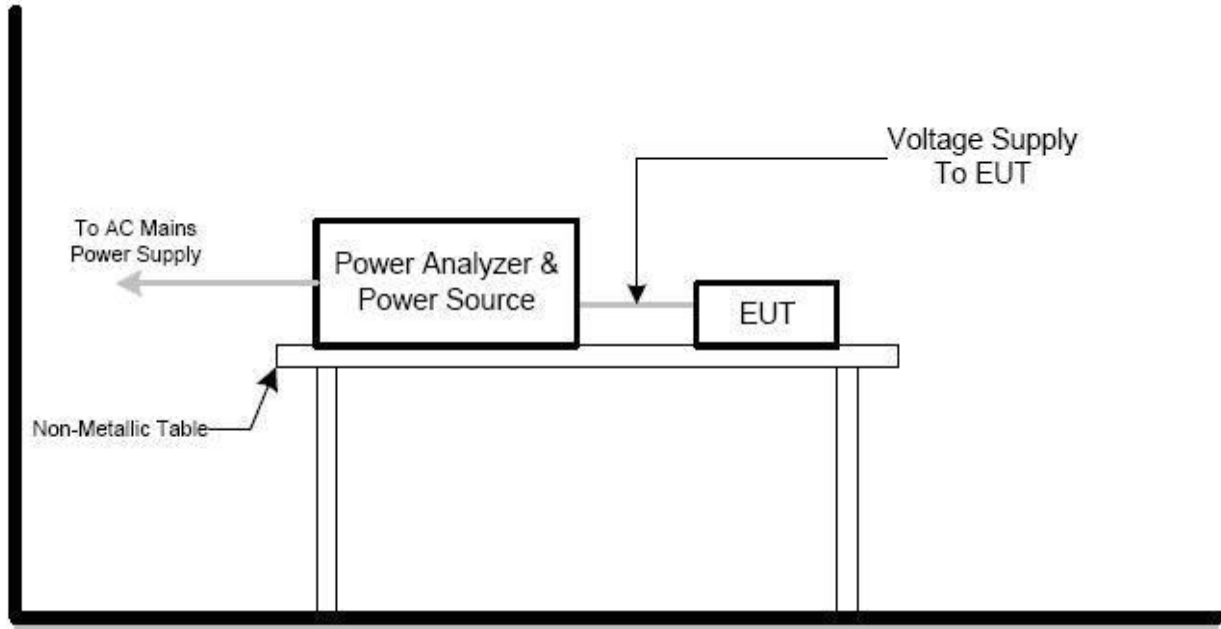

3.3.2 TEST RESULTS

EUT:	LoRa RF Transceiver Module	Model Name:	LoRa 1276-C1-868
Temperature:	25 °C	Relative Humidity:	45%
Pressure:	1010 hPa	Test Power :	N/A
Note:	N/A		

Not applicable

3.4 VOLTAGE FLUCTUATION AND FLICKERS

3.4.1 LIMITS OF VOLTAGE FLUCTUATION AND FLICKERS

Test items	Limits(EN61000-3-3)	Descriptions
P_{st}	$\leq 1.0, T_p=10\text{min}$	short-term flicker indicator
P_{lt}	$\leq 0.65, T_p=2\text{h}$	long-term flicker indicator
d_c	$\leq 3.3\%$	relative steady-state voltage change
d_{max}	$\leq 4\%$ (or 6% ^{Note(1)} , 7% ^{Note(2)})	maximum relative voltage change:
$d_{(t)}$	$\leq 3.3\%$, more than 500ms	relative voltage change characteristic

Note:

1. 6 % for equipment which is:
 - a. switched manually, or
 - b. switched automatically more frequently than twice per day, and also has either a delayed restart (the delay being not less than a few tens of seconds), or manual restart, after a power supply interruption.
2. 7 % for equipment which is
 - a. attended whilst in use (for example: hair dryers, vacuum cleaners, kitchen equipment such as mixers, garden equipment such as lawn mowers, portable tools such as electric drills), or
 - b. switched on automatically, or is intended to be switched on manually, no more than twice per day, and also has either a delayed restart (the delay being not less than a few tens of seconds) or manual restart, after a power supply interruption.

3.4.1.1 TEST PROCEDURE

a. Harmonic Current Test:

Test was performed according to the procedures specified in Sub-clause 6.2 of IEC/EN 61000-3-2 depend on which standard adopted for compliance measurement.

b. Fluctuation and Flickers Test:

Tests was performed according to the Test Conditions/Assessment of Voltage Fluctuations specified in Clause 6.0/4.0 of IEC/EN 61000-3-3 depend on which standard adopted for compliance measurement.

c. All types of harmonic current and/or voltage fluctuation in this report are assessed by direct measurement using flicker-meter.

3.4.1.2 EUT OPERATING CONDITIONS

The EUT tested system was configured as the statements of **2.3** Unless otherwise a special operating condition is specified in the follows during the testing.

3.4.1.3 TEST SETUP

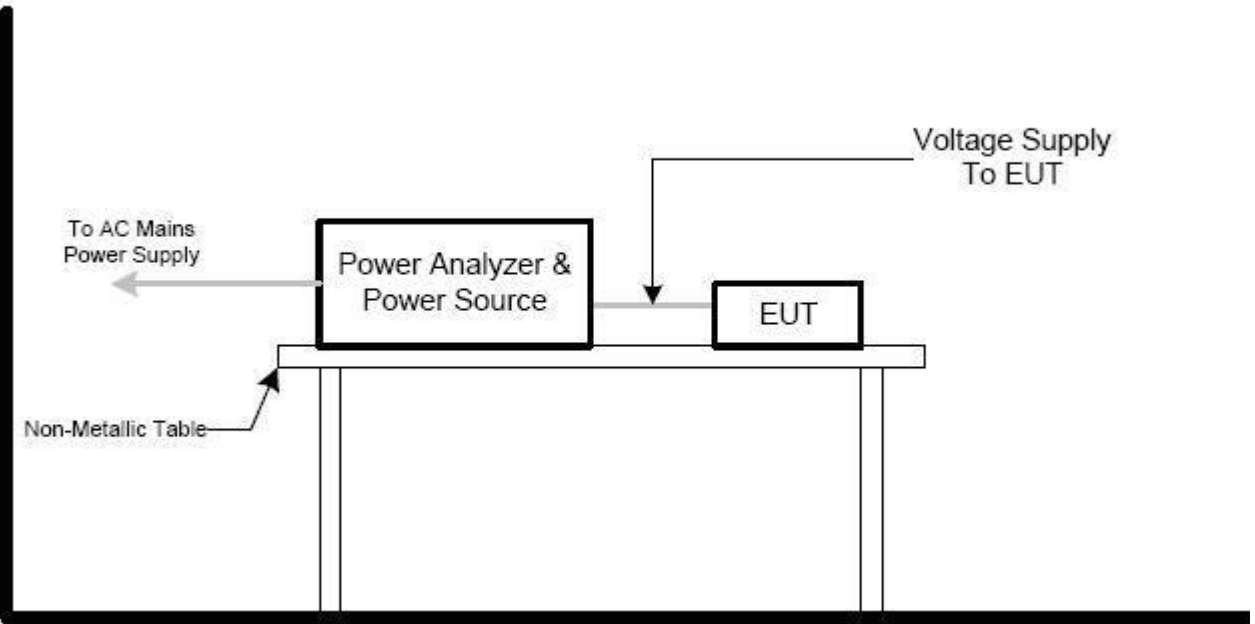

3.4.2 TEST RESULTS

EUT:	LoRa RF Transceiver Module	Model Name:	LoRa 1276-C1-868
Temperature:	25 °C	Relative Humidity:	45%
Pressure:	1010 hPa	Test Power :	N/A
Note:	N/A		

4. EMC IMMUNITY TEST

4.1 STANDARD COMPLIANCE/SERVIRITY LEVEL/CRITERIA

Tests Standard No.	TEST SPECIFICATION	Test Mode Test Ports	Perform. Criteria
1. ESD IEC/EN 61000-4-2	8KV air discharge 4KV contact discharge	Direct Mode	B
	4KV HCP discharge 4KV VCP discharge	Indirect Mode	B
2. RS IEC/EN 61000-4-3	80 MHz to 6000 MHz, 1000Hz, 80%, AM modulated	Enclosure	A
3. EFT/Burst IEC/EN 61000-4-4	5/50ns Tr/Th 5KHz Repetition Freq.	Power Supply Port	B
	5/50ns Tr/Th 5KHz Repetition Freq.	CTL/Signal Data Line Port	B
4. Surges IEC/EN 61000-4-5	1.2/50(8/20) Tr/Th us	L-N	B
	1.2/50(8/20) Tr/Th us	L-PE N-PE	B
5 Injected Current IEC/EN 61000-4-6	0.15 MHz to 80 MHz, 1000Hz 80% , AM Modulated 150Ω source impedance	CTL/Signal Port	A
	0.15 MHz to 80 MHz, 1000Hz 80% , AM Modulated 150Ω source impedance	AC Power Port	A
	0.15 MHz to 80 MHz, 1000Hz 80% , AM Modulated 150Ω source impedance	DC Power Port	A
6. Volt. Interruptions Volt. Dips IEC/EN 61000-4-11	Voltage dip 100%	AC Power Port	B
	Voltage dip 30%		C
	Interruption 100%		C

4.2 GENERAL PERFORMANCE CRITERIA

According to **(Final Draft)EN 301 489-3** standard, the general performance criteria as following:

SRD equipment		
Criteria	During the test	After the test
A	Operate as intended No loss of function No unintentional responses	Operate as intended No loss of function No degradation of performance No loss of stored data or user programmable functions
B	May show loss of function No unintentional responses	Operate as intended Lost function(s) shall be self-recoverable No degradation of performance No loss of stored data or user programmable functions

4.3 GENERAL PERFORMANCE CRITERIA TEST SETUP

The EUT tested system was configured as the statements of 2.3 Unless otherwise a special operating condition is specified in the follows during the testing.

4.4 ESD TESTING

4.4.1 TEST SPECIFICATION

Basic Standard:	IEC/EN 61000-4-2
Discharge Impedance:	330 ohm / 150 pF
Required Performance	B
Discharge Voltage:	Air Discharge:2kV/4kV/8kV (Direct) Contact Discharge:2kV/4kV (Direct/Indirect)
Polarity:	Positive & Negative
Number of Discharge:	Air Discharge: min. 20 times at each test point Contact Discharge: min. 200 times in total
Discharge Mode:	Single Discharge
Discharge Period:	1 second minimum

4.4.2 TEST PROCEDURE

The test generator necessary to perform direct and indirect application of discharges to the EUT in the following manner:

- a. Contact discharge was applied to conductive surfaces and coupling planes of the EUT.

During the test, it was performed with single discharges. For the single discharge time between successive single discharges was at least 1 second.

Vertical Coupling Plane (VCP):

The coupling plane, of dimensions 0.5m x 0.5m, is placed parallel to, and positioned at a distance 0.1m from, the EUT, with the Discharge Electrode touching the coupling plane.

The four faces of the EUT will be performed with electrostatic discharge.

Horizontal Coupling Plane (HCP):

The coupling plane is placed under to the EUT. The generator shall be positioned vertically at a distance of 0.1m from the EUT, with the Discharge Electrode touching the coupling plane.

The four faces of the EUT will be performed with electrostatic discharge.

- b. Air discharges at insulation surfaces of the EUT.

It was at least ten single discharges with positive and negative at the same selected point.

4.4.3 TEST SETUP

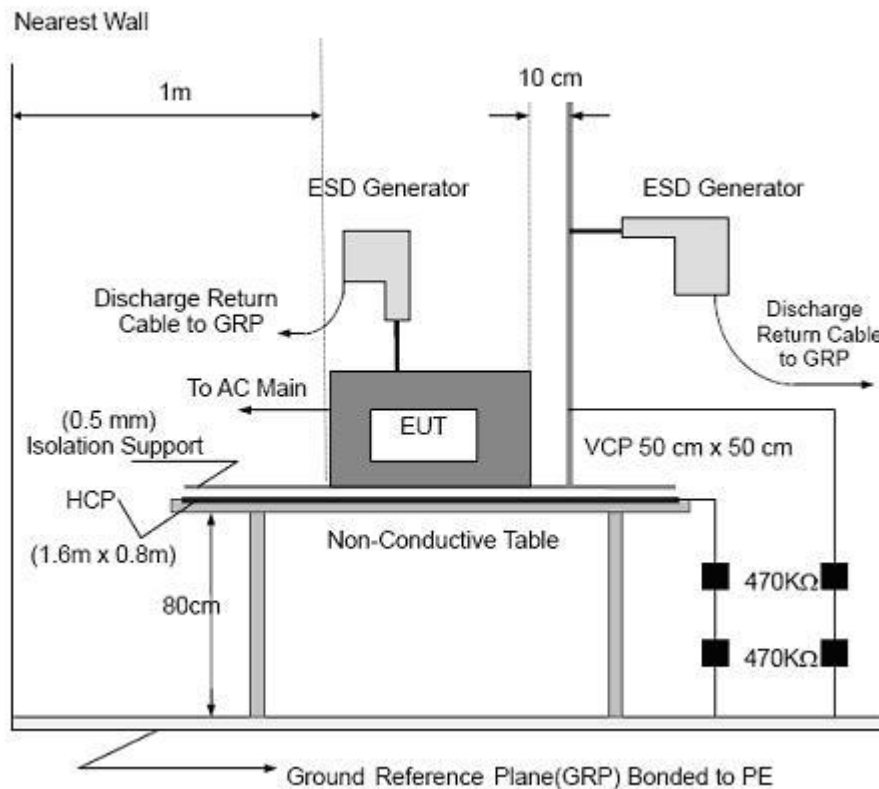

Note:

TABLE-TOP EQUIPMENT

The configuration consisted of a wooden table 0.8 meters high standing on the Ground Reference Plane. The GRP consisted of a sheet of aluminum at least 0.25mm thick, and 2.5 meters square connected to the protective grounding system. A Horizontal Coupling Plane (1.6m x 0.8m) was placed on the table and attached to the GRP by means of a cable with 940k total impedance. The equipment under test, was installed in a representative system as described in section 7 of IEC /EN 61000-4-2, and its cables were placed on the HCP and isolated by an insulating support of 0.5mm thickness. A distance of 1-meter minimum was provided between the EUT and the walls of the laboratory and any other metallic structure.

FLOOR-STANDING EQUIPMENT

The equipment under test was installed in a representative system as described in section 7 of IEC/EN 61000-4-2, and its cables were isolated from the Ground Reference Plane by an insulating support of 0.1-meter thickness. The GRP consisted of a sheet of aluminum that is at least 0.25mm thick, and 2.5meters square connected to the protective grounding system and extended at least 0.5 meters from the EUT on all sides.

4.4.4 TEST RESULTS

EUT:	LoRa RF Transceiver Module	Model Name:	LoRa 1276-C1-868
Temperature:	25 °C	Relative Humidity:	45%
Pressure:	1010 hPa	Test Mode:	Mode1
Test Power:	DC 3.3V		

Mode	Contact Discharge (Indirect)							Criterion	Result
Test level (kV)	Test Point	2		4		6			
Test Location		+	-	+	-	+	-		
HCP	Front	P	P	P	P			B	Complies
	Rear	P	P	P	P				
	Left	P	P	P	P				
	Right	P	P	P	P				
VCP	Front	P	P	P	P				
	Rear	P	P	P	P				
	Left	P	P	P	P				
	Right	P	P	P	P				

4.5 RS TESTING

4.5.1 TEST SPECIFICATION

Basic Standard:	IEC/EN 61000-4-3
Required Performance	A
Frequency Range:	80 MHz - 6000 MHz
Field Strength:	3 V/m
Modulation:	1kHz Sine Wave, 80%, AM Modulation
Frequency Step:	1 % of fundamental
Polarity of Antenna:	Horizontal and Vertical
Test Distance:	3 m
Antenna Height:	1.5 m
Dwell Time:	at least 3 seconds

4.5.2 TEST PROCEDURE

The EUT and support equipment, which are placed on a table that is 0.8 meter above ground and the testing was performed in a fully-anechoic chamber.

The testing distance from antenna to the EUT was 3 meters.

The other condition as following manner:

- a. The field strength level was 3V/m.
- b. The frequency range is swept from 80 MHz to 6000MHz with the signal 80%amplitude modulated with a 1kHz sine wave. The rate of sweep did not exceed 1.5×10^{-3} decade/s. Where the frequency range is swept incrementally, the step size was 1% of fundamental.
- c. Sweep Frequency 900 MHz, with the Duty Cycle:1/8 and Modulation: Pulse 217 Hz(if applicable)
- d. The dwell time at each frequency shall be not less than the time necessary for the EUT to be able to respond.

4.5.3 TEST SETUP

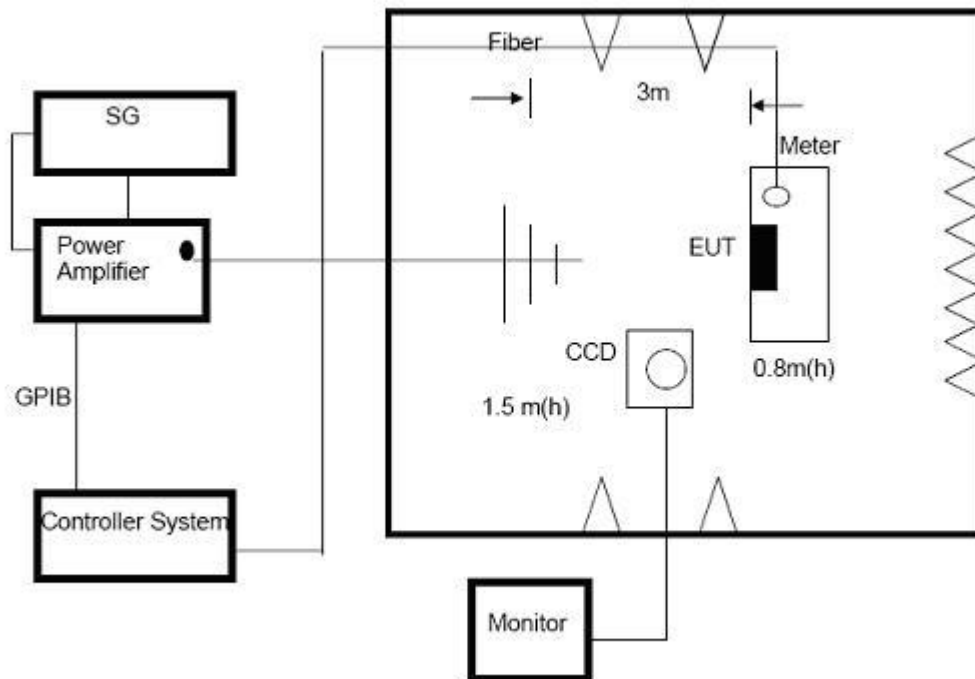

Note:

TABLE-TOP EQUIPMENT

The EUT installed in a representative system as described in section 7 of IEC/EN 61000-4-3 was placed on a non-conductive table 0.8 meters in height. The system under test was connected to the power and signal wire according to relevant installation instructions.

FLOOR-STANDING EQUIPMENT

The EUT installed in a representative system as described in section 7 of IEC/EN 61000-4-3 was placed on a non-conductive wood support 0.1 meters in height. The system under test was connected to the power and signal wire according to relevant installation instructions.

4.5.4 TEST RESULTS

EUT:	LoRa RF Transceiver Module	Model Name:	LoRa 1276-C1-868
Temperature:	25 °C	Relative Humidity:	60%
Pressure:	1010 hPa	Test Mode:	Mode1
Test Power:	DC 3.3V		

Frequency Range (MHz)	RF Field Position	R.F. Field Strength	Azimuth	Observation	Perform. Criteria	Results
80~1000	H / V	3 V/m (rms) AM Modulated 1000Hz, 80%	Front	CT,CR	A	P
			Rear			
			Left			
			Right			

Frequency Range (MHz)	RF Field Position	R.F. Field Strength	Azimuth	Observation	Perform. Criteria	Results
1000~6000	H / V	3 V/m (rms) AM Modulated 1000Hz, 80%	Front	CT,CR	A	P
			Rear			
			Left			
			Right			

Note: "A" stand for, during test, operate as intended no loss of function, no degradation of performance, no unintentional transmissions and after test, no degradation of performance, no loss of function, no loss of stored data or user programmable functions.

Note:

- 1) N/A - denotes test is not applicable in this test report.
- 2) There was not any unintentional transmission in standby mode
- 3) In the table: 'P' represents 'PASS'; 'F' represents 'FAIL'.

4.6 EFT/BURST TESTING

4.6.1 TEST SPECIFICATION

Basic Standard:	IEC/EN 61000-4-4
Required Performance	B
Test Voltage:	Power Line:1 kV Signal/Control Line:0.5 KV
Polarity:	Positive & Negative
Impulse Frequency:	5 kHz
Impulse Wave shape :	5/50 ns
Burst Duration:	15 ms
Burst Period:	300 ms
Test Duration:	Not less than 1 min.

4.6.2 TEST PROCEDURE

The EUT and support equipment, are placed on a table that is 0.8 meter above a metal ground plane measured 1m*1m min. and 0.65mm thick min.

The other condition as following manner:

- a. The length of power cord between the coupling device and the EUT should not exceed 1 meter.
- b. Both positive and negative polarity discharges were applied.
- c. The duration time of each test sequential was 1 minute
- d. For the actual test configuration, please refer to the related Item –EUT Test Photos.

4.6.3 TEST SETUP

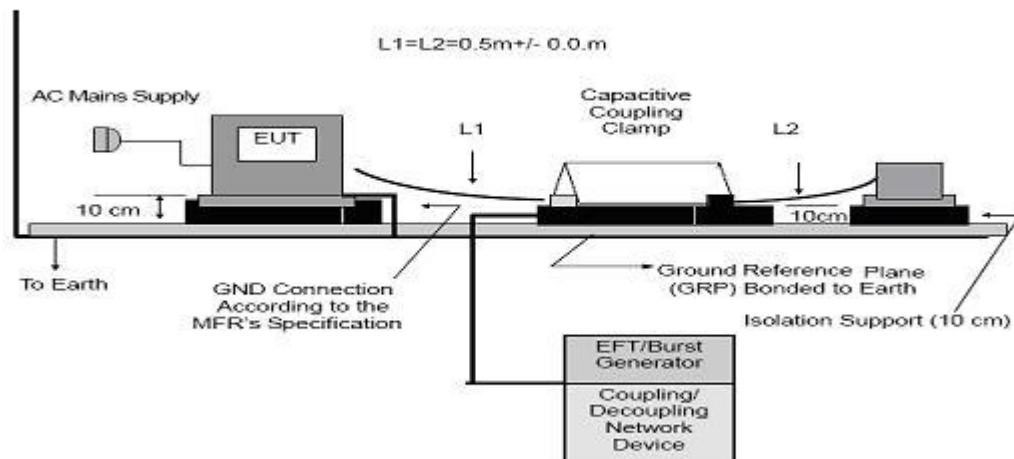
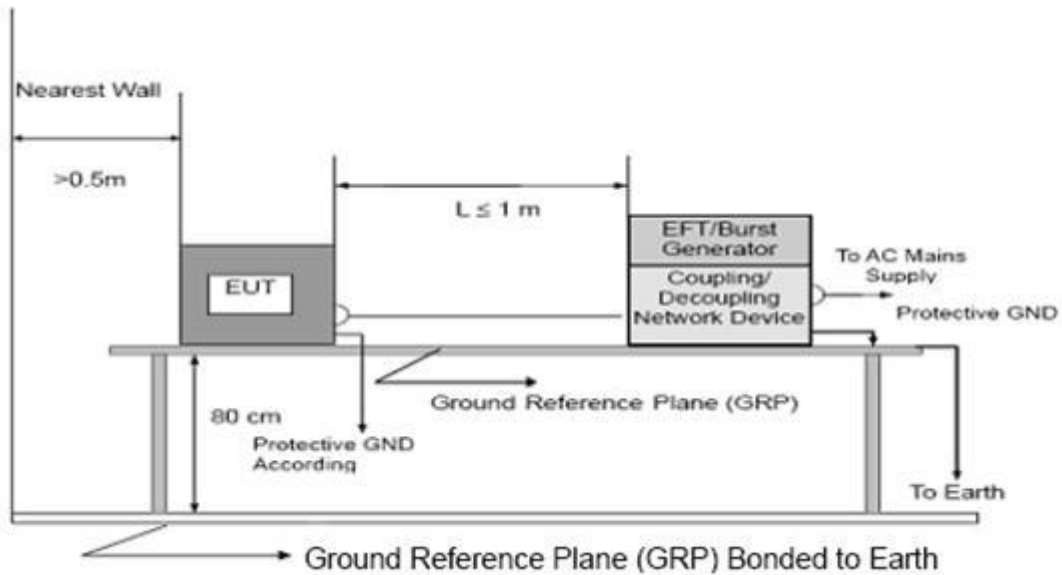

Note:

TABLE-TOP EQUIPMENT

The configuration consisted of a wooden table (0.8m high) standing on the Ground Reference Plane. The GRP consisted of a sheet of aluminum (at least 0.25mm thick and 2.5m square) connected to the protective grounding system. A minimum distance of 0.5m was provided between the EUT and the walls of the laboratory or any other metallic structure.

FLOOR-STANDING EQUIPMENT

The EUT installed in a representative system as described in section 7 of IEC/EN 61000-4-4 and its cables, were isolated from the Ground Reference Plane by an insulating support that is 0.1-meter thick. The GRP consisted of a sheet of aluminum (at least 0.25mm thick and 2.5m square) connected to the protective grounding system.

4.6.4 TEST RESULTS

EUT:	LoRa RF Transceiver Module	Model Name:	LoRa 1276-C1-868
Temperature:	25 °C	Relative Humidity:	60%
Pressure:	1010 hPa	Test Power :	N/A
Note:	N/A		

4.7 SURGE TESTING

4.7.1 TEST SPECIFICATION

Basic Standard:	IEC/EN 61000-4-5
Required Performance	B
Wave-Shape:	Combination Wave 1.2/50 us Open Circuit Voltage 8 /20 us Short Circuit Current
Test Voltage:	Power Line:0.5 kV, 1 kV, 2 kV
Surge Input/Output:	L-N, L-PE, N-PE
Generator Source:	2 ohm between networks
Impedance:	12 ohm between network and ground
Polarity:	Positive/Negative
Phase Angle:	0 /90/180/270°
Pulse Repetition Rate:	1 time / min. (maximum)
Number of Tests:	5 positive and 5 negative at selected points

4.7.2 TEST PROCEDURE

a. For EUT power supply:

The surge is to be applied to the EUT power supply terminals via the capacitive coupling network. Decoupling networks are required in order to avoid possible adverse effects on equipment not under test that may be powered by the same lines, and to provide sufficient decoupling impedance to the surge wave. The power cord between the EUT and the coupling/decoupling networks shall be 2meters in length (or shorter).

b. For test applied to unshielded unsymmetrically operated interconnection lines of EUT:

The surge is applied to the lines via the capacitive coupling. The coupling /decoupling networks shall not influence the specified functional conditions of the EUT. The interconnection line between the EUT and the coupling/decoupling networks shall be 2 meters in length (or shorter).

c. For test applied to unshielded symmetrically operated interconnection /telecommunication lines of EUT:

d. The surge is applied to the lines via gas arrestors coupling. Test levels below the ignition point of the coupling arrestor cannot be specified. The interconnection line between the EUT and the coupling/decoupling networks shall be 2 meters in length (or shorter).

4.7.3 TEST SETUP

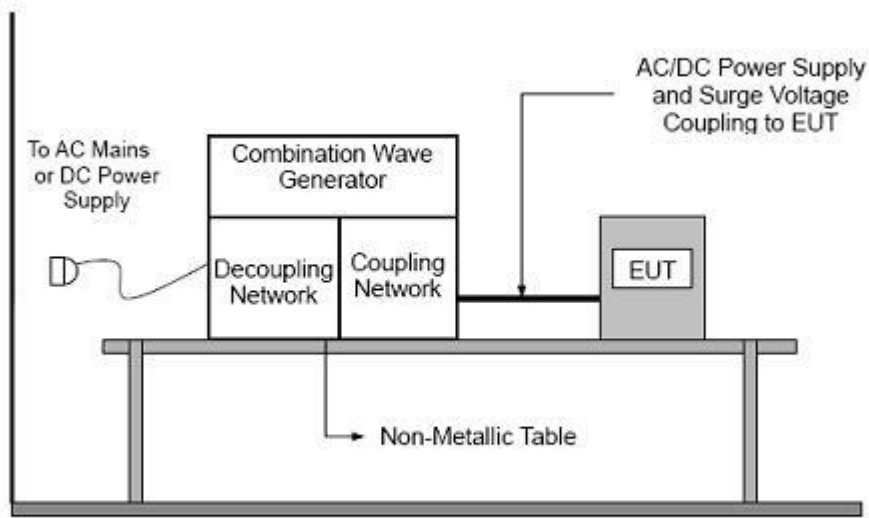

4.7.4 TEST RESULTS

EUT:	LoRa RF Transceiver Module	Model Name:	LoRa 1276-C1-868
Temperature:	25 °C	Relative Humidity:	60%
Pressure:	1010 hPa	Test Power :	N/A
Note:	N/A		

4.8 INJECTION CURRENT TESTING

4.8.1 TEST SPECIFICATION

Basic Standard:	IEC/EN 61000-4-6
Required Performance	A
Frequency Range:	0.15 MHz - 80 MHz
Field Strength:	3 Vr.m.s.
Modulation:	1kHz Sine Wave, 80%, AM Modulation
Frequency Step:	1 % of fundamental
Dwell Time:	at least 3 seconds

4.8.2 TEST PROCEDURE

The EUT and support equipment, are placed on a table that is 0.8 meter above a metal ground plane measured 1m*1m min. and 0.65mm thick min.

The other condition as following manner:

- a. The frequency range is swept from 150 KHz to 80 MHz, with the signal 80%amplitude modulated with a 1kHz sine wave. The rate of sweep did not exceed 1.5×10^{-3} decade/s. Where the frequency range is swept incrementally, the step size was 1% of fundamental.
- b. The dwell time at each frequency shall be not less than the time necessary for the EUT to be able to respond.

4.8.3 TEST SETUP

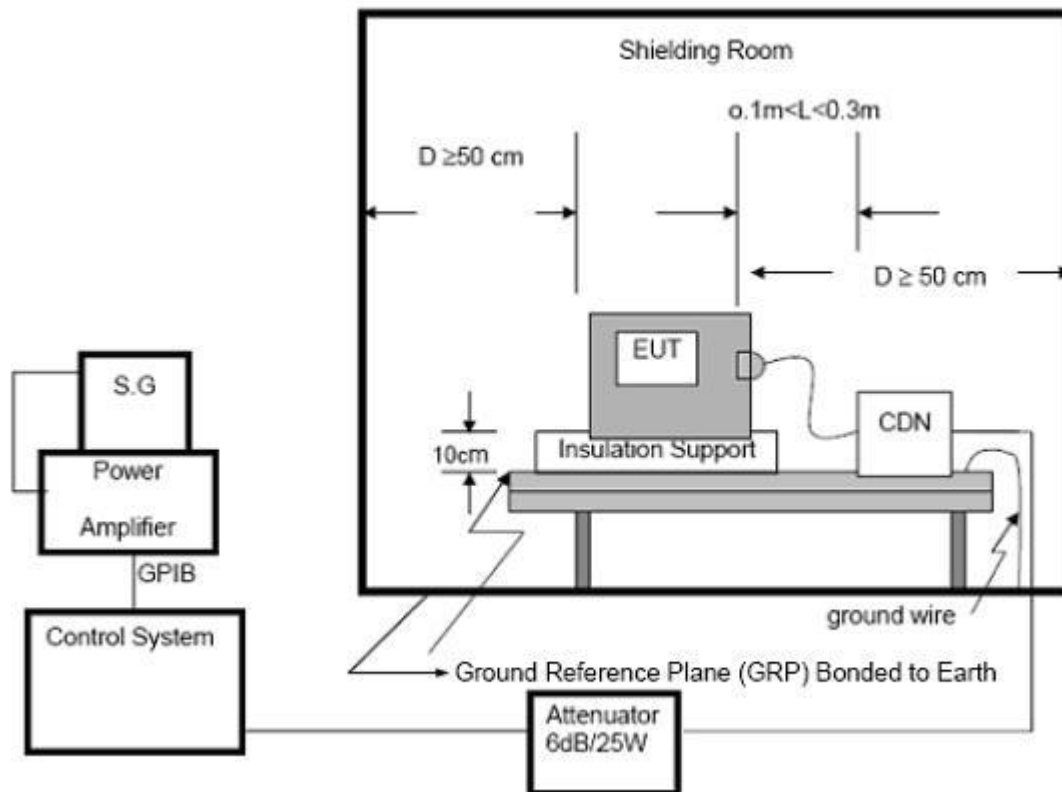

NOTE:

FLOOR-STANDING EQUIPMENT

The equipment to be tested is placed on an insulating support of 0.1 meters height above a ground reference plane. All relevant cables shall be provided with the appropriate coupling and decoupling devices at a distance between 0.1 meters and 0.3 meters from the projected geometry of the EUT on the ground reference plane.

4.8.4 TEST RESULTS

EUT:	LoRa RF Transceiver Module	Model Name:	LoRa 1276-C1-868
Temperature:	25 °C	Relative Humidity:	60%
Pressure:	1010 hPa	Test Power :	N/A
Note:	N/A		

4.9 VOLTAGE INTERRUPTION/DIPS TESTING

4.9.1 TEST SPECIFICATION

Basic Standard:	IEC/EN 61000-4-11
Required Performance	B (For 100% Voltage Dips) C (For 30% Voltage Dips) C (For 100% Voltage Interruptions)
Test Duration Time:	Minimum three test events in sequence
Interval between Event:	Minimum ten seconds
Phase Angle:	0°/45°/90°/135°/180°/225°/270°/315°/360°
Test Cycle:	3 times

4.9.2 TEST PROCEDURE

The EUT shall be tested for each selected combination of test levels and duration with a sequence of three dips/interruptions with intervals of 10 s minimum (between each test event). Each representative mode of operation shall be tested. Abrupt changes in supply voltage shall occur at zero crossings of the voltage waveform.

4.9.3 TEST SETUP

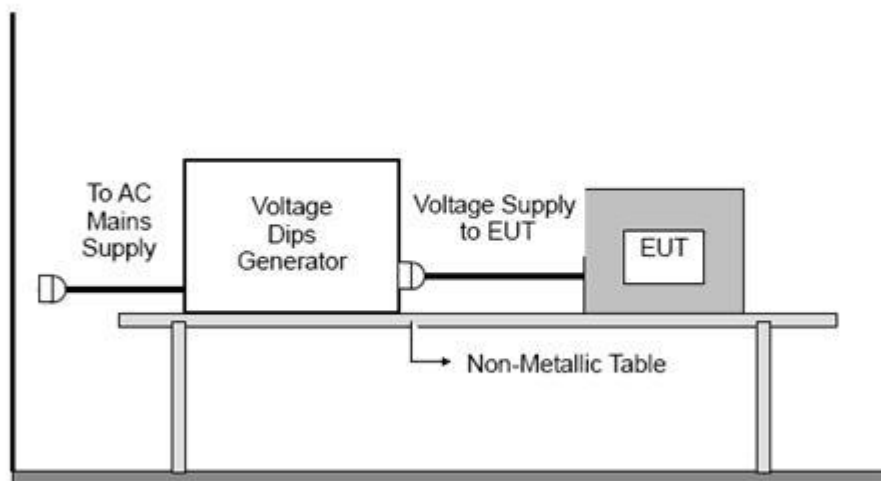

4.9.4 TEST RESULTS

EUT:	LoRa RF Transceiver Module	Model Name:	LoRa 1276-C1-868
Temperature:	25 °C	Relative Humidity:	60%
Pressure:	1010 hPa	Test Power :	N/A
Note:	N/A		

5. EUT TEST PHOTO

Radiated Measurement Photos((30-1000MHz)

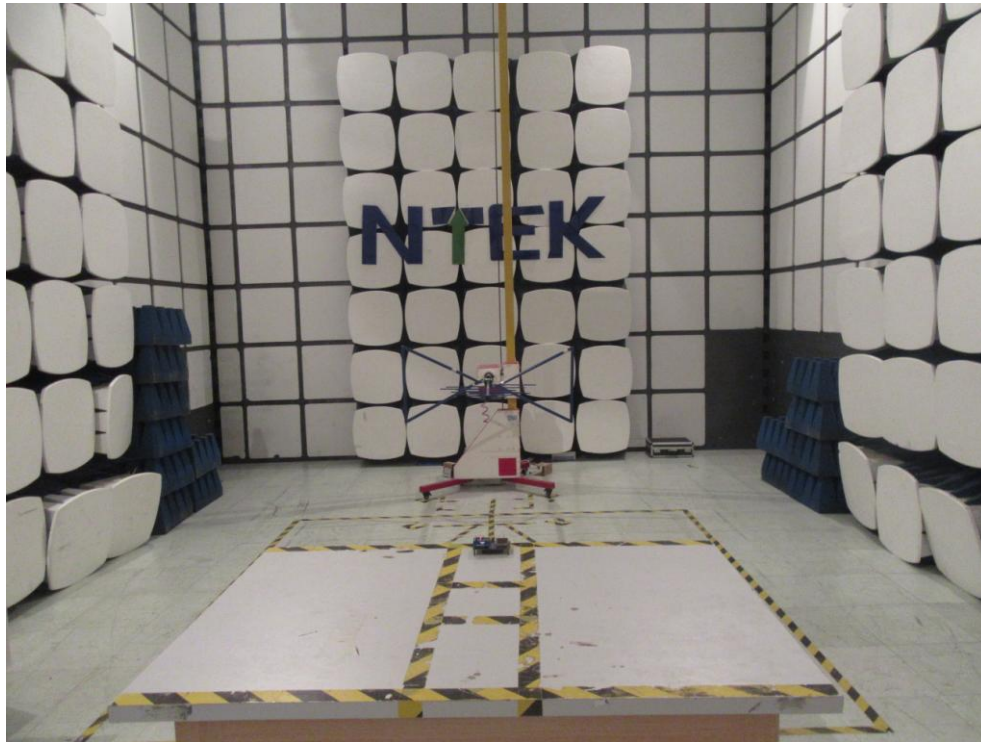

Radiated Measurement Photos(1-6G)

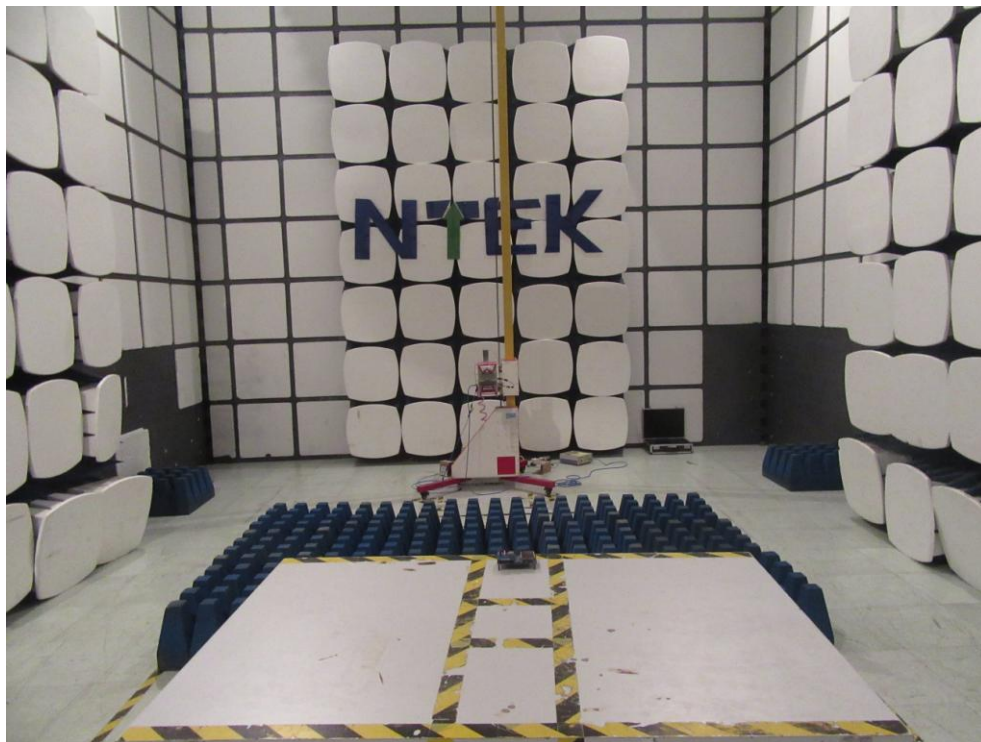

RS

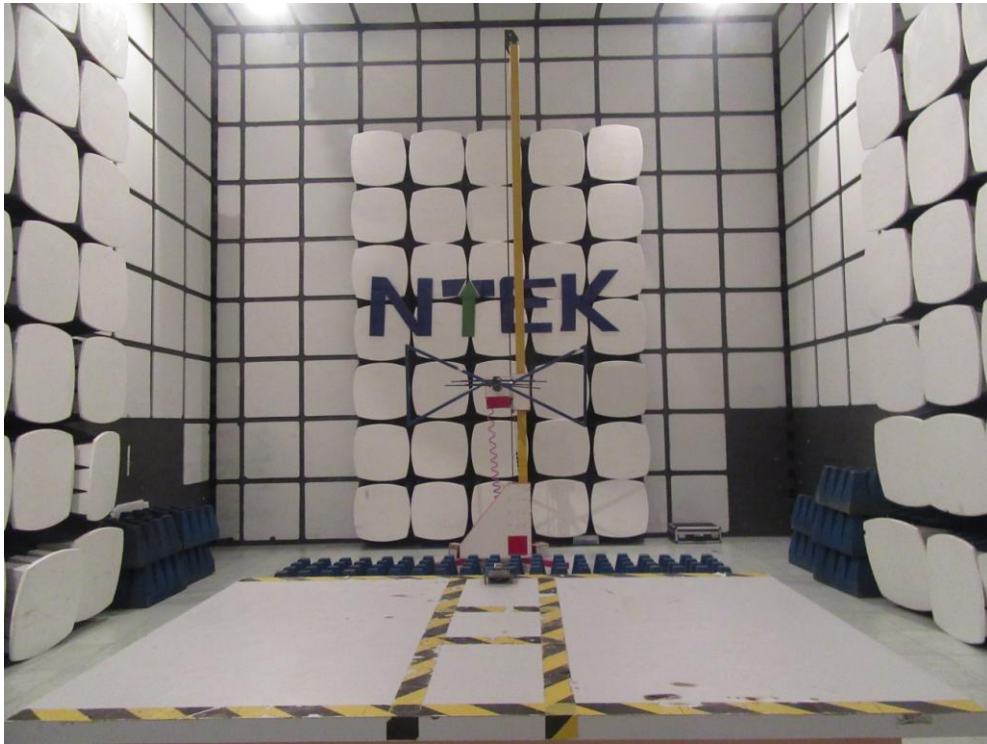

ESD

