

TF03-180 is a industrial high-speed LiDAR with a range of up to 180m. TF03-180 includes compensation algorithms for outdoor glare and other interference, so it works normally under strong light environment and rain, fog and snow conditions[®]. Different built-in operating modes let customers change parameters and configuration to meet their need.



■ Technical specifications

Two versions of TF03-180 are available to customers who have different interface and power supply requirements:

- 1) Standard version supports TTL serial port and CAN interface with 5V power supply (If 6-24V power supply is needed, please contact sales).
- 2) RS485/RS232 version supports RS485/RS232 interface with 6-24V power supply.

Parameters name		Standard version	RS485/RS232 version
Performance	Operating range	0.1m-180m@90% reflectivity 0.1m-70m@10% reflectivity 0.1m-130m@90% reflectivity&100Klux 0.1m-50m@10% reflectivity&100Klux	
	Accuracy ^②	±10cm (within 10m), 1% (10m and further)	
	Distance resolution	1cm	
	Frame rate ^③	1Hz~1000Hz adjustable (default 100Hz)	
	Repeatability	1σ: <3cm	
	Ambient light immunity	100Klux	
	Operation temperature	-25~60°C	
	Enclosure rating	IP67	
Optical parameters	Light source	LD	
	Central wavelength	905nm	
	Photobiological safety	CLASS1(EN60825)	
	FOV ^④	0.5°	
Electrical parameters	Supply voltage	5V±0.5V	6V-24V
	Average current Peak current	≤180mA	≤200mA @ 6V; ≤100mA @ 12V; ≤50mA @ 24V
	Power consumption	≤0.9W	≤1.2W
	Communication interface level	LVTTL(3.3V)	RS485/RS232
	Communication interface	UART/CAN/IO	RS485/RS232

Parameters name		Standard version	RS485/RS232 version
Others	Dimension	44mm*43mm*32mm(L*W*H)	
	Enclosure material	Aluminum alloy	
	Storage temperature	-40~85°C	
	Weight	77g±3g	80g±3g
	Cable length	70cm	

Notes:① Rain, snow and fog conditions generally refer to moderate rain, snow and below, and moderate rainfall < 25mm/24h or < 7.9mm/h.

② Accuracy and repeatability are measured in white board (90% reflectivity) and will be somewhat different in the case of different reflectivity or light sensitivity conditions.

③ The highest frame rate can be customized for 10KHz.

④ FOV of light spot, horizontal is different with vertical, the detection angle in the parameters table means the maximum one, which means the horizontal one. Note:Lidar's horizontal axis and light spot's axis are same when logo face up.

Product dimensions

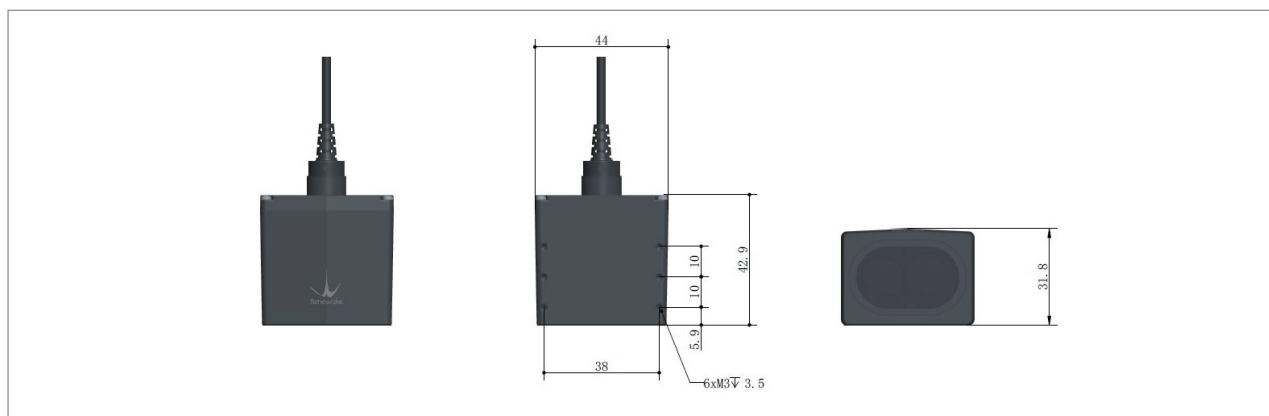

TF03-180 dimensions (Left 1: top view; Left 2: upward view; Left 3: front view) Unit: mm

Communication protocol

TF03-180 standard version supports TTL serial port as default, and CAN communication mode is also available to use if needed. Command are provided for modifying to CAN mode, but only one of the two modes are working, two of them cannot output at the same time.

TF03-180 RS485/RS232 version supports RS485 and RS232 communication modes at the same time. By default, both interfaces can communicate, and different interface lines can be used.

TF03-180 serial port communication protocol

Communication Protocol	UART/RS485/RS232
Baud rate	115200
Data bit	8
Stop bit	1
Checksum bit	N/A

TF03-180 CAN communication protocol

Communication Protocol	CAN
Baud rate	1000K
Receiving ID	0x3003
Sending ID	0x3
Frame format	Default sending frame is standard frame, receiving frame support standard frame and extended frame

■ Configurable parameters

Configurable item	Description	Factory configuration
Custom frame rate	Detection frame rate could be configured by related command, range 1~1000Hz	100Hz
Over range output	This value will be pushed output when measuring value more than this value	180m
Output format	Serial port/Pixhawk/IO/CAN	Serial port
Custom baud rate	a) Serial port baud rate could be customized b) CAN port baud rate could be customized, CAN ID could be changed	/
Factory reset	TF03-180 can be restored to the factory settings via tf03_setup GUI software	/
Configuration saved when power cut	Parameters could be saved when power cut by related command	/

Note: More configuration parameters and command could be found in the production manual.

■ Product Certification



Benewake(Beijing) Co., Ltd.

ADD.: No.28 Xinxu Road, Haidian District, Beijing, China

Tel: +86-010-57456983

Email: bw@benewake.com(The company)

support@benewake.com(Technical support)