

Assembly Instructions for  
**goBILDA® Linear Actuator Kit**  
SKU: 3212-0001-0001

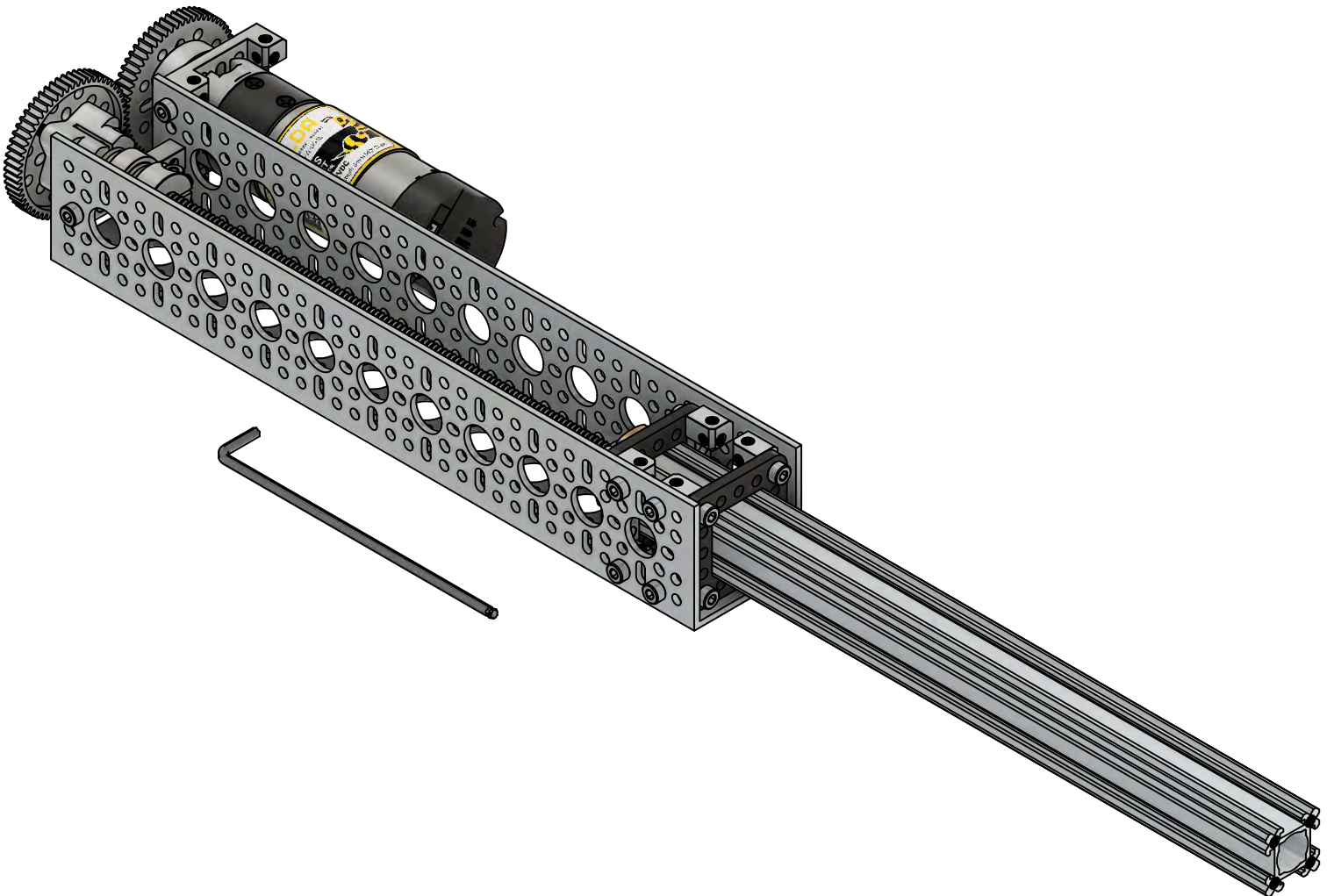

Motor Not Included

# Kit Contents

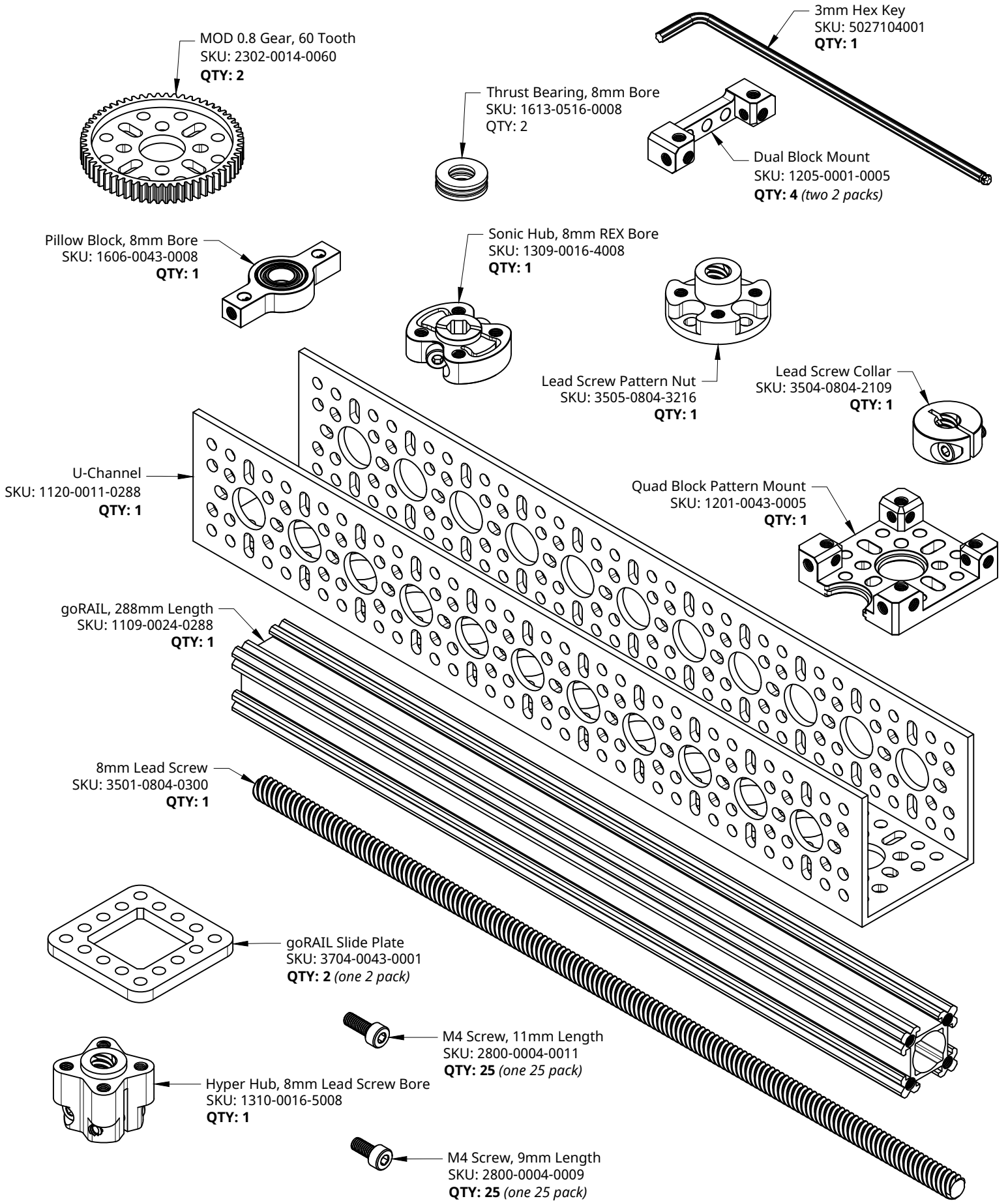

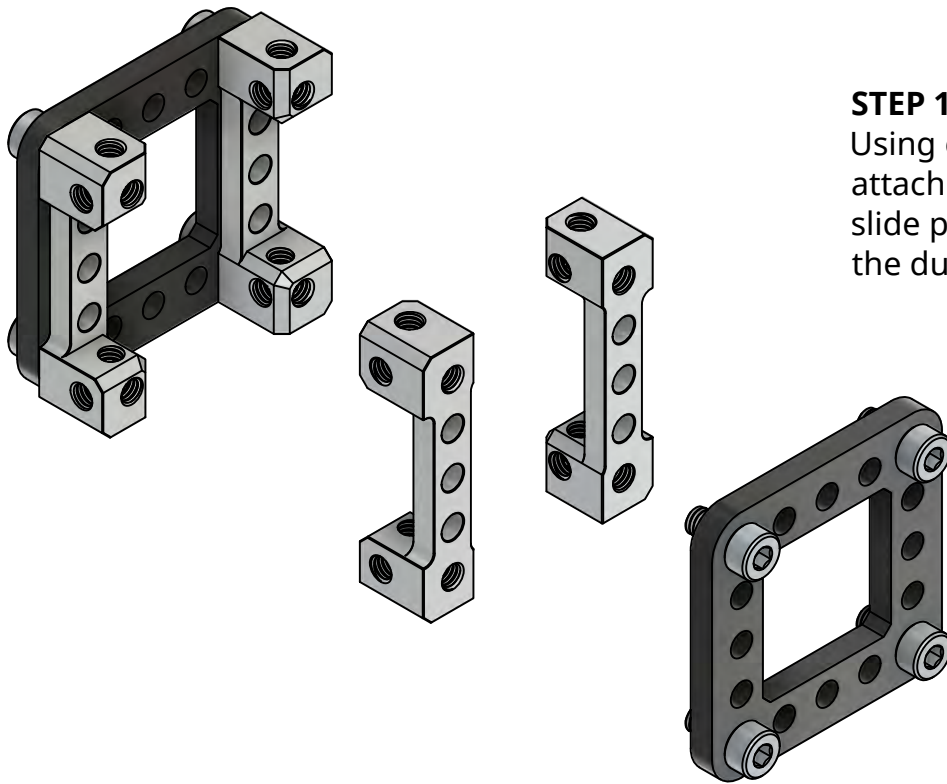

**STEP 1**

Using eight 9mm length M4 screws, attach the dual block mounts to the slide plates. Note the orientation of the dual block mounts.

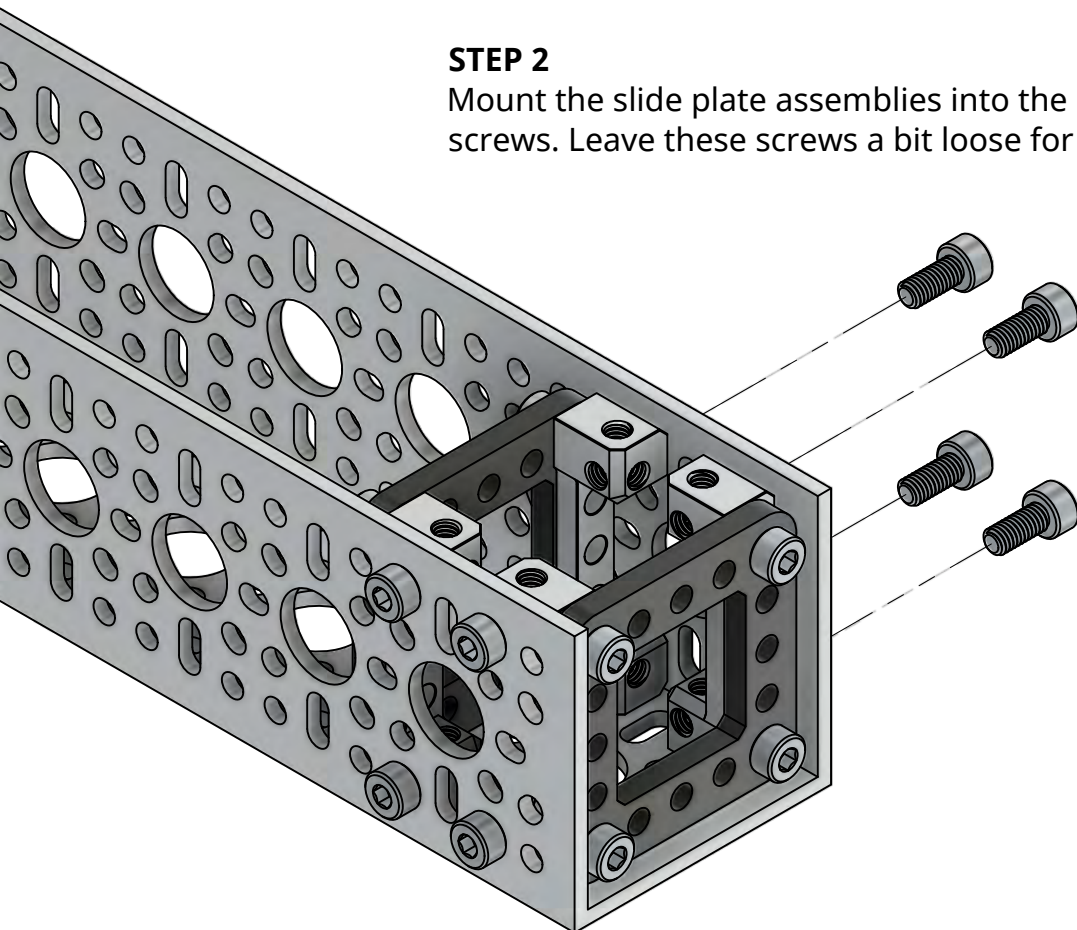

**STEP 2**

Mount the slide plate assemblies into the channel using eight 9mm M4 screws. Leave these screws a bit loose for now.

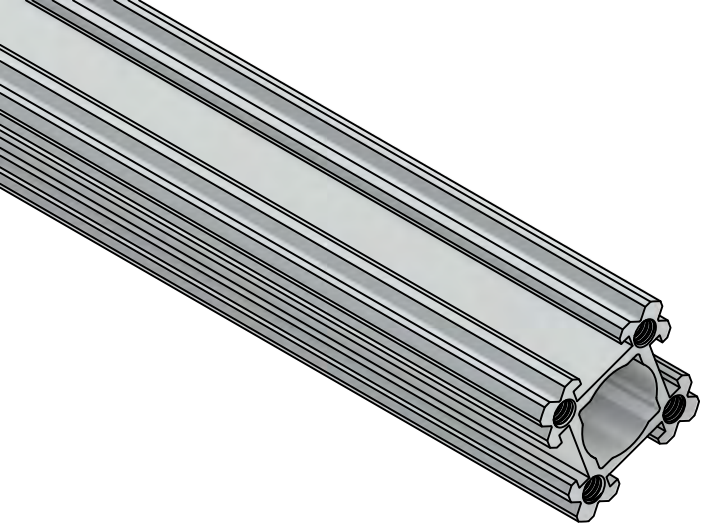

### STEP 3

Use four 11mm M4 screws to attach the lead screw nut to the end of the goRAIL.

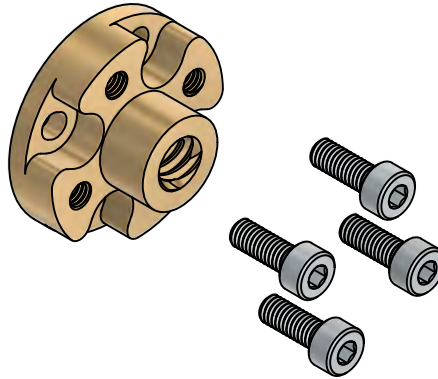

### STEP 4

Thread the lead screw into the lead screw nut.

Slide the goRAIL assembly into the slide plates, then tighten the four screws from Step 2.

Thread the collar and one thrust bearing onto the lead screw. Do not tighten the collar's pinch bolt yet.

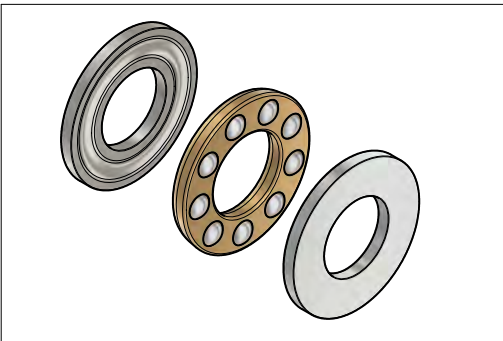
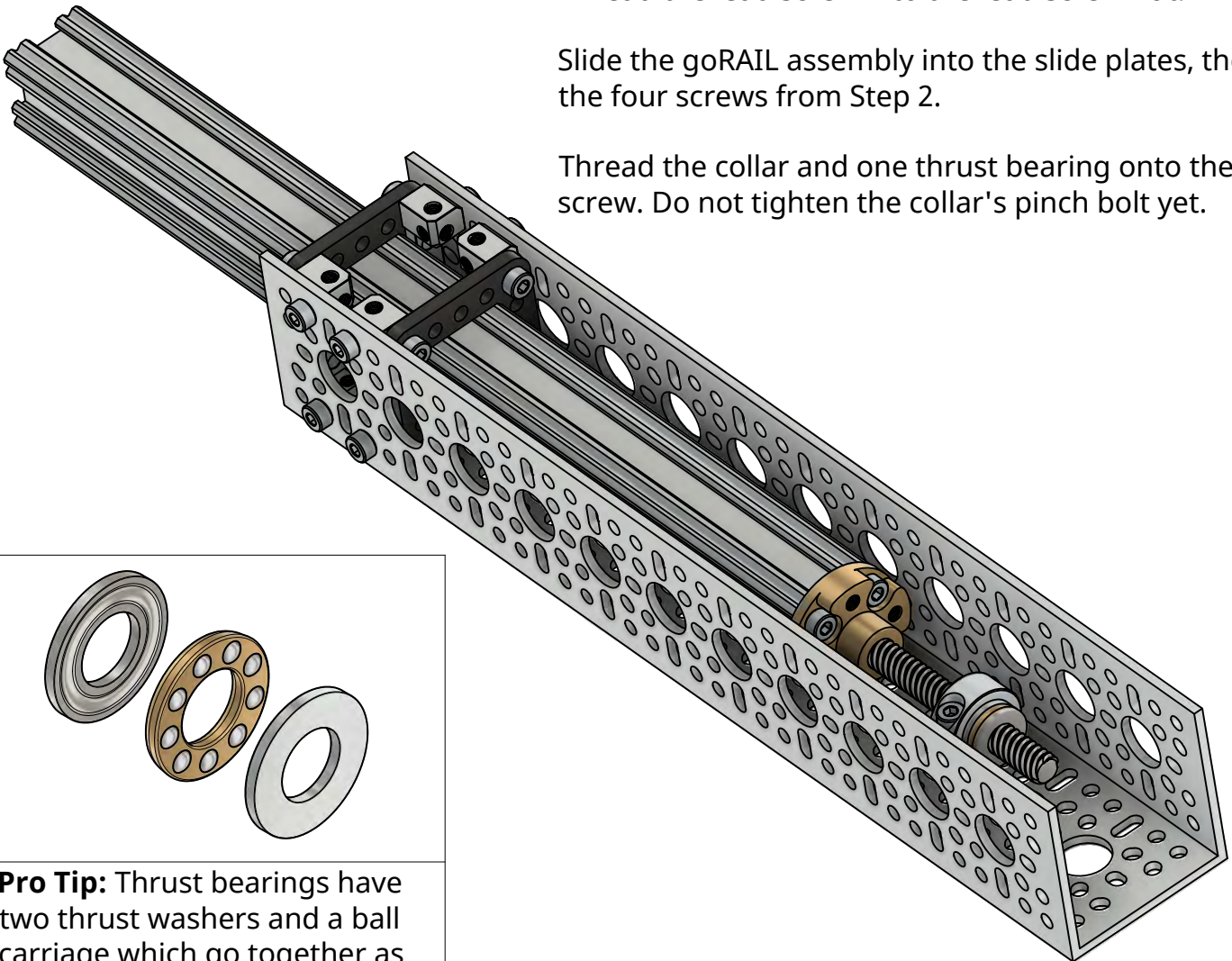

**Pro Tip:** Thrust bearings have two thrust washers and a ball carriage which go together as shown here, with the grooves towards the balls.

### STEP 5

Slide the pillow block onto the lead screw. It does not matter which end of the pillow block faces forward.

Align the threaded holes with the back of the slot in the channel as shown. Fasten the pillow block with two 11mm length M4 screws.

Slide the other thrust bearing onto the lead screw.

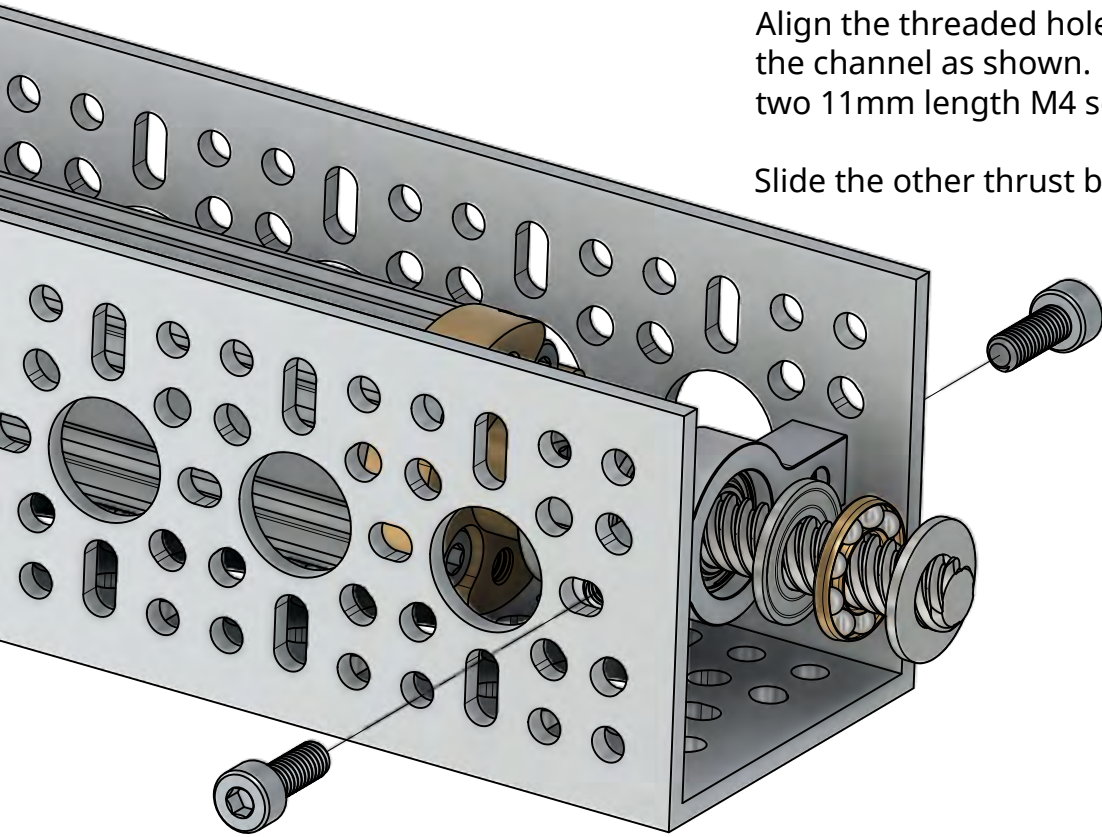

### STEP 6

Attach the Quad Block Pattern Mount with two 11mm M4 screws. Note its orientation.

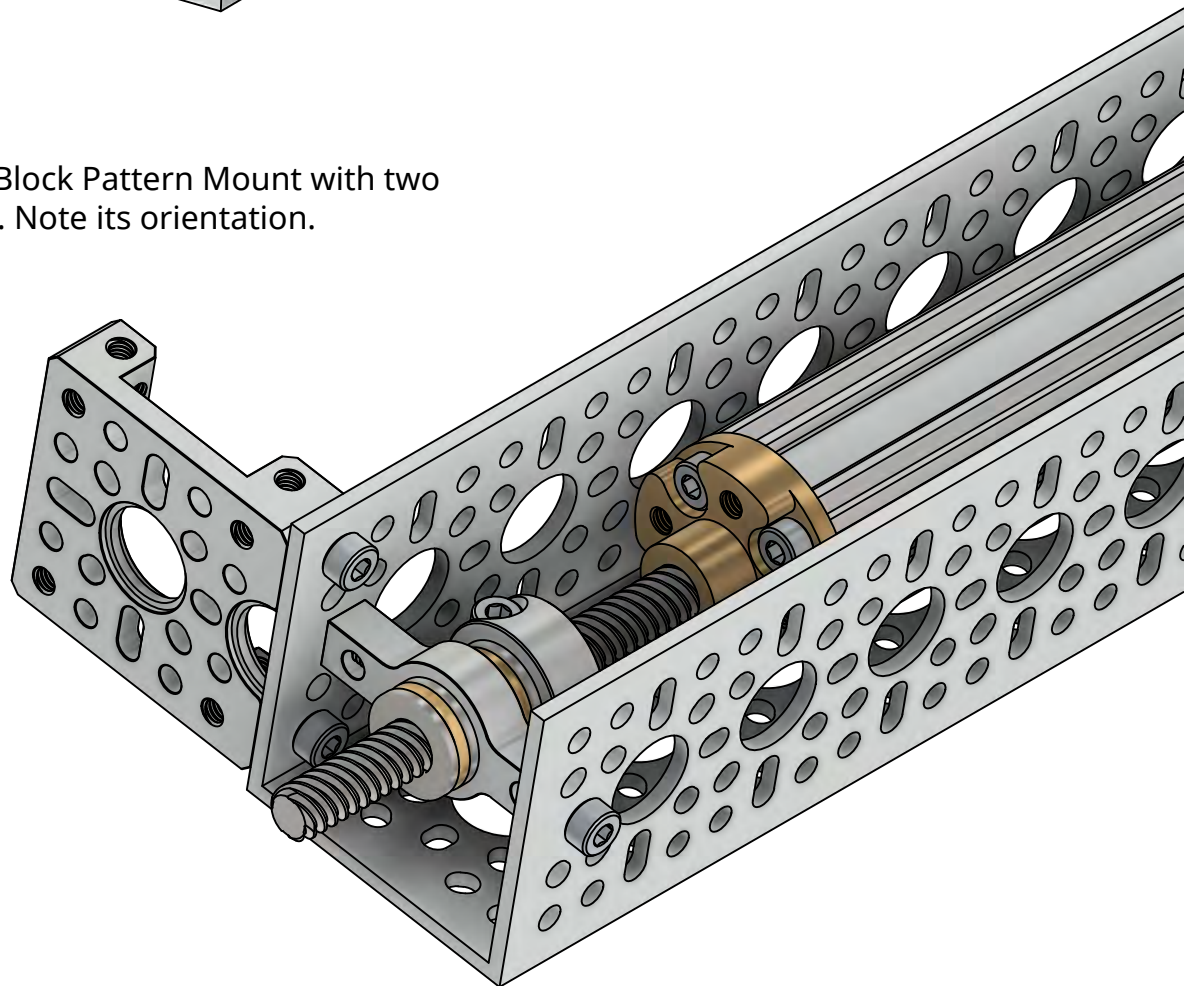

## STEP 7

Fasten a motor to the Quad Block Pattern Mount with four 11mm M4 screws. This kit does not include a motor; a 5203-2402-0005 is shown as an example.

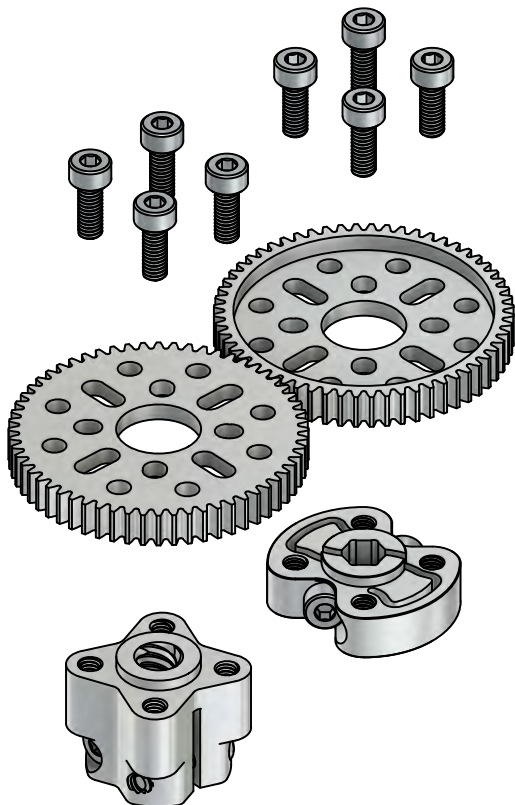
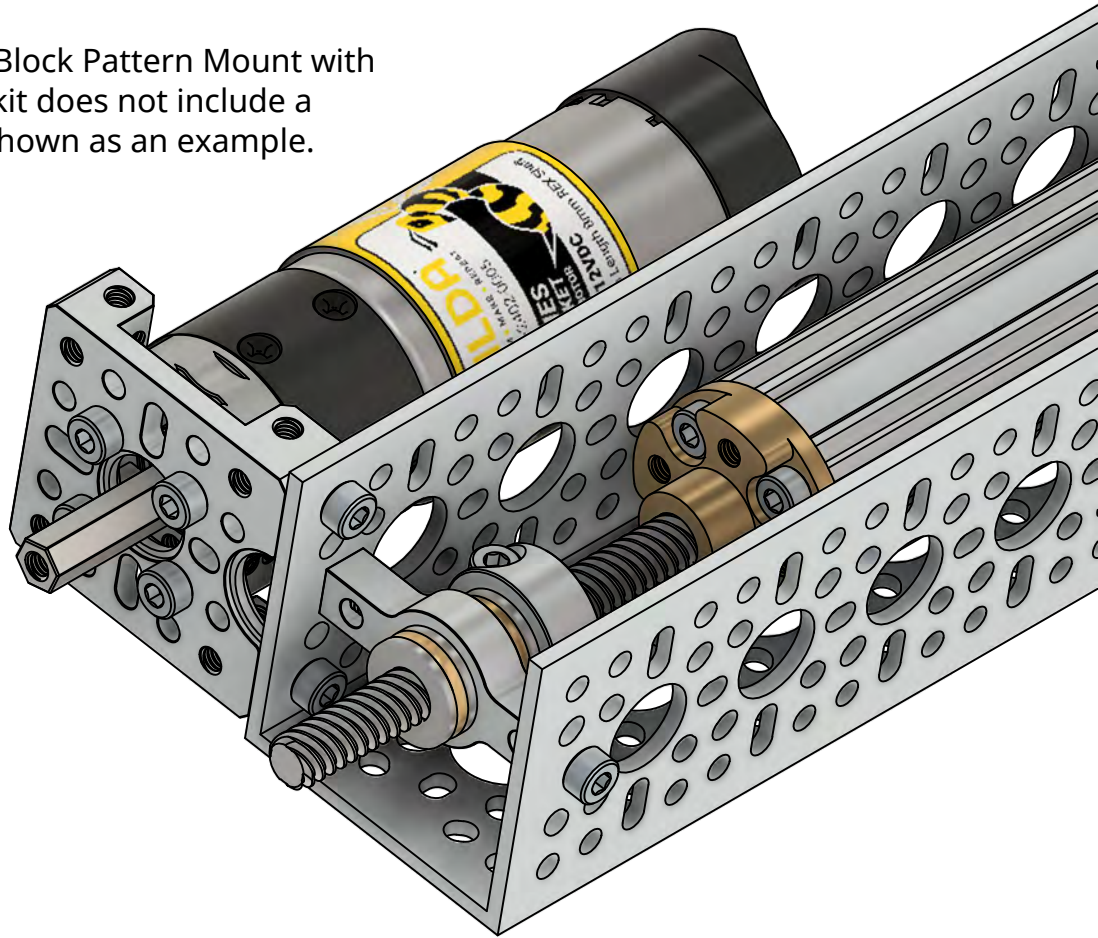

## STEP 8

Mount the hubs to the gears as shown using eight 11mm M4 screws. Note the gear orientation. Position the one that gets attached to the 8mm lead screw bore hub so the "dished out" portion of the gear is facing toward the hub.

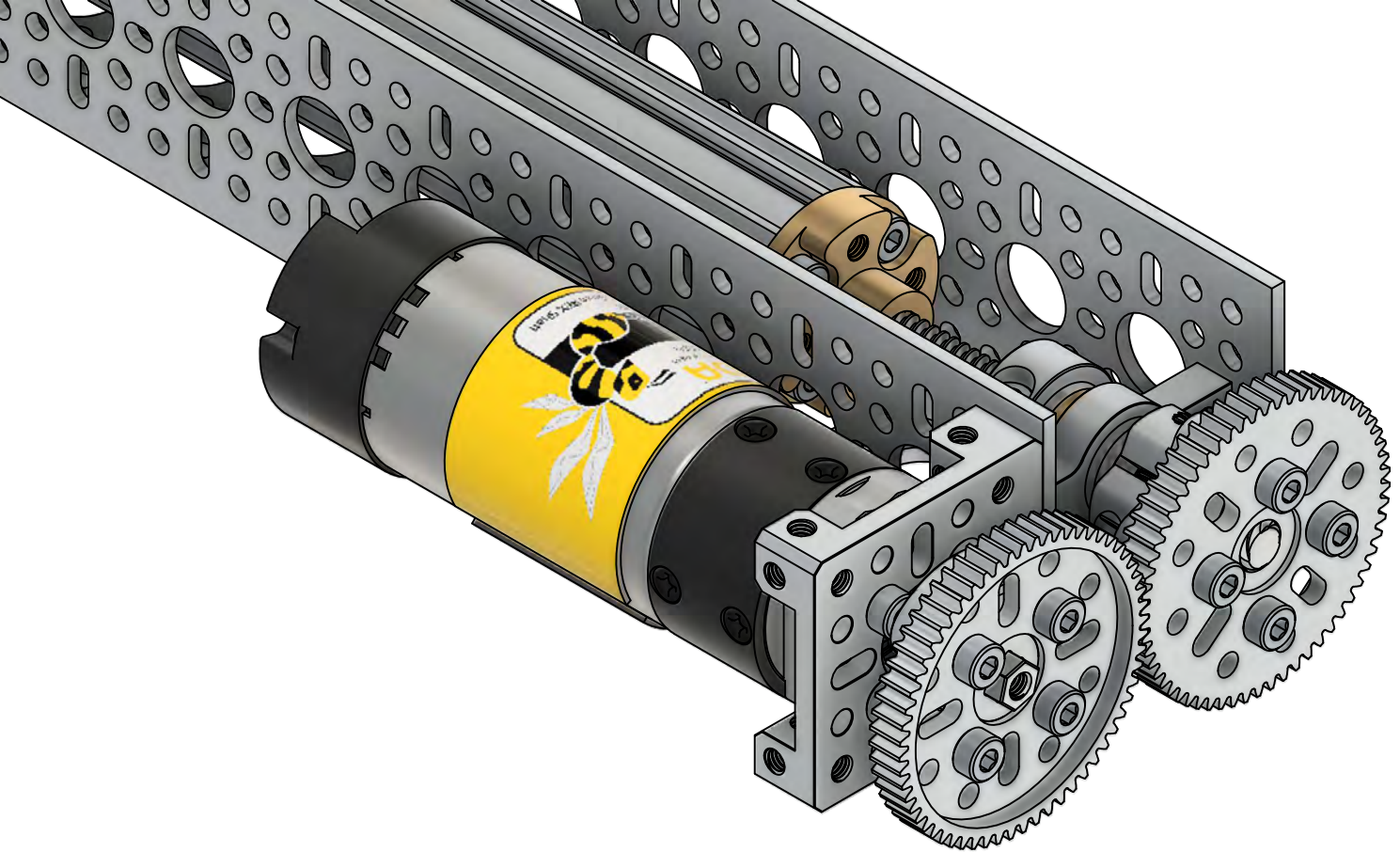

### STEP 9

- Ensure the clamping collar is contacting the nearby thrust bearing.
- Thread the Hyper Hub gear assembly onto the lead screw until it contacts the other thrust bearing.
- With both firmly against their respective thrust bearing, tighten the pinch bolts on the collar and hub.
- Slide the Sonic Hub gear assembly onto the motor shaft.
- Adjust the Sonic Hub's location on the shaft until both gears are axially flush with one another.
- Tighten the pinch bolts on the Sonic Hub.

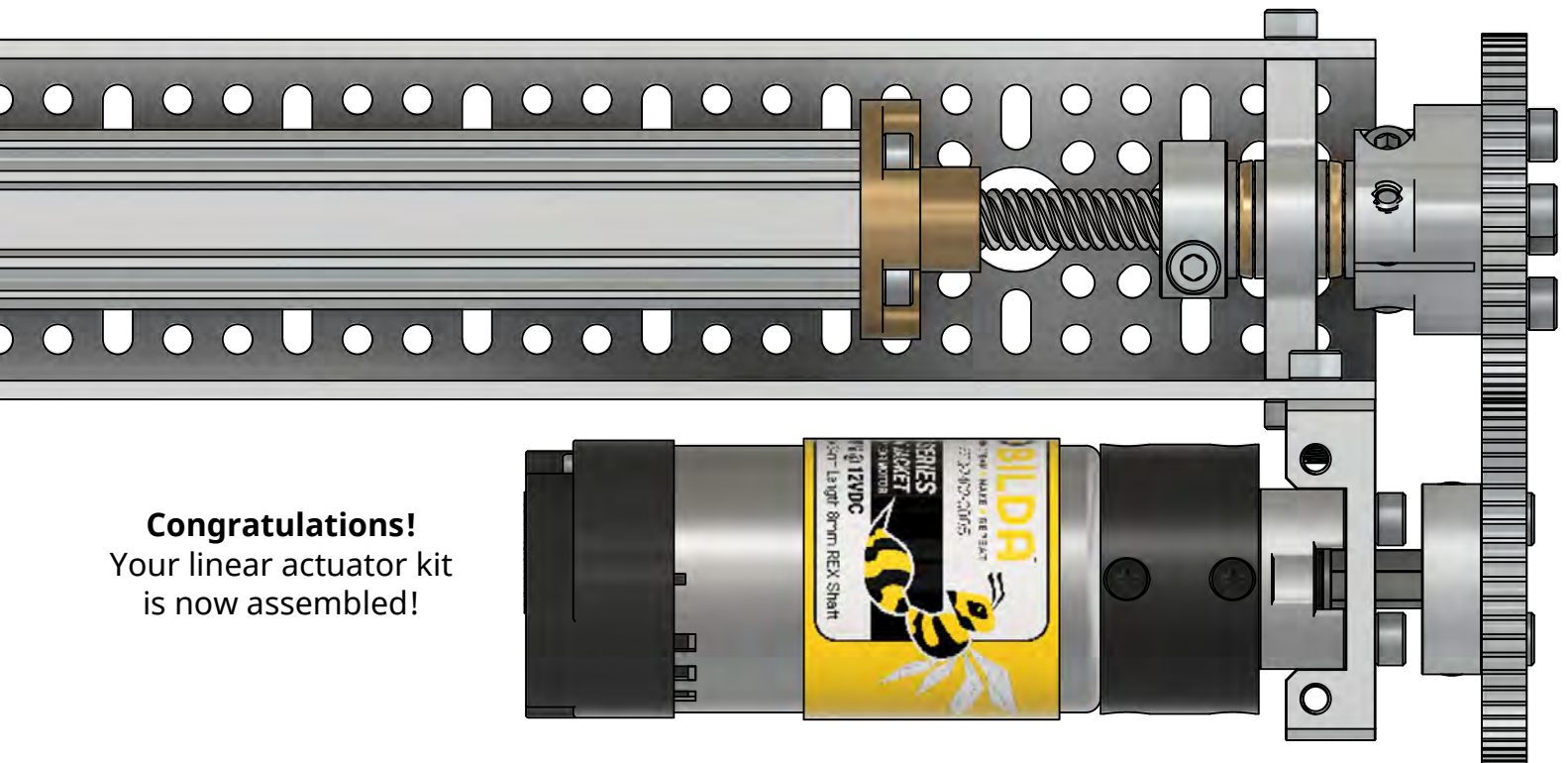

**Congratulations!**  
Your linear actuator kit  
is now assembled!