



ESSENTIAL INFORMATION

BUILD INSTRUCTIONS
CHECKING YOUR PCB & FAULT-FINDING
MECHANICAL DETAILS
HOW THE KIT WORKS

DESIGN AN EDGE LIT DISPLAY PIECE WITH THIS

5V LED Strip Kit

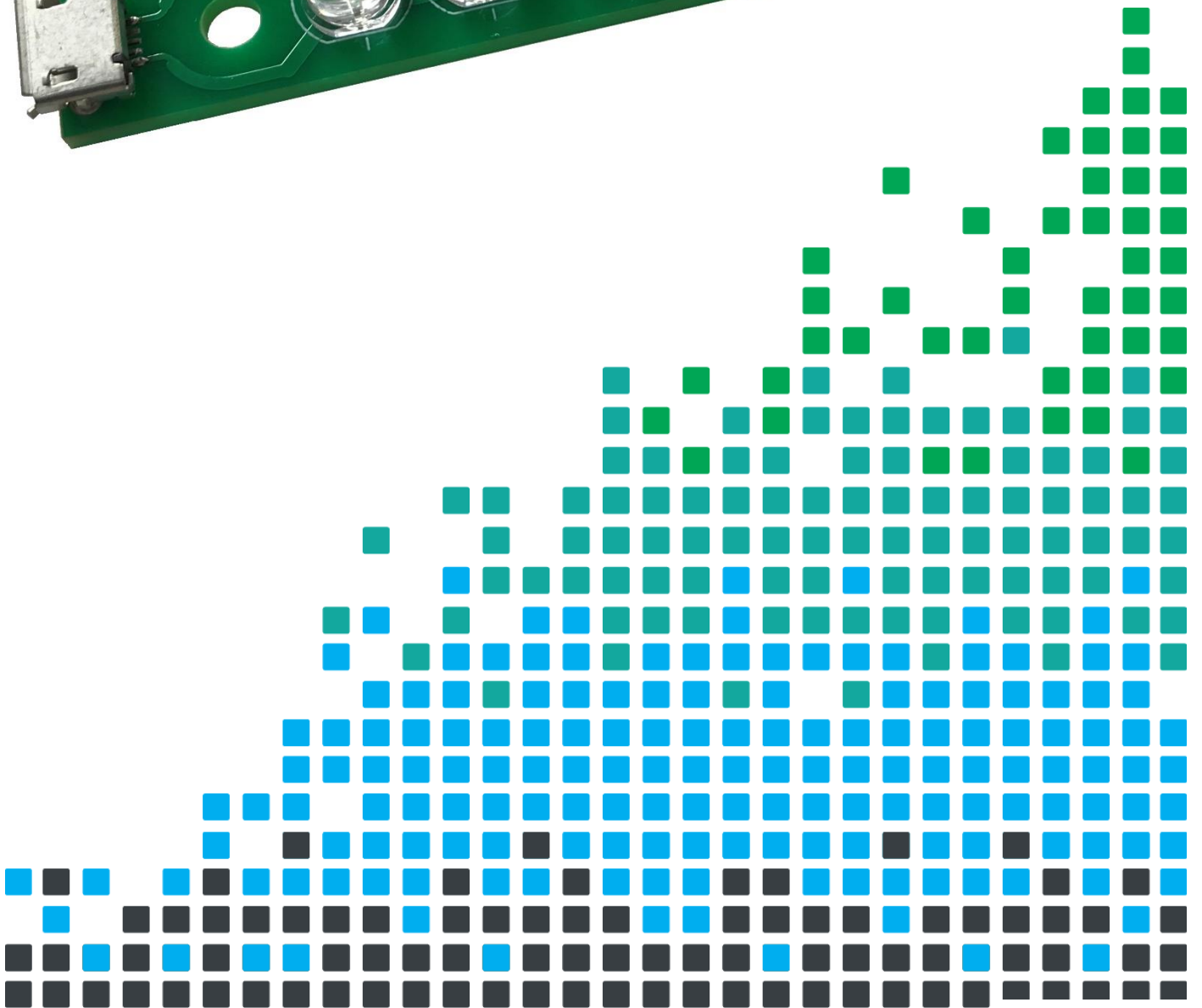

Version 1.0

Build Instructions

Before you start, take a look at the Printed Circuit Board (PCB). The components go in the side with the writing on and the solder goes on the side with the tracks and silver pads.

1

PLACE THE SWITCH

Place the switch into the three holes at the end. Make sure the switch actuator sticks out from the end of the PCB.

Solder the switch and trim the legs.



2

PLACE THE LEDs

Place the 4 LEDs.

Make sure they are the correct way round. The PCB silk screen indicates the shape – line up the flat side as shown. Additionally, the longer leg goes in the hole marked with the +.

Solder the LEDs and trim the legs.



Checking Your 5V LED Strip PCB

- Have you soldered all the components in? There should be no unused component holes. Only the mounting holes should be empty.
- Is the LED orientation correct? (Does the outline of the LED match the markings on the PCB?)

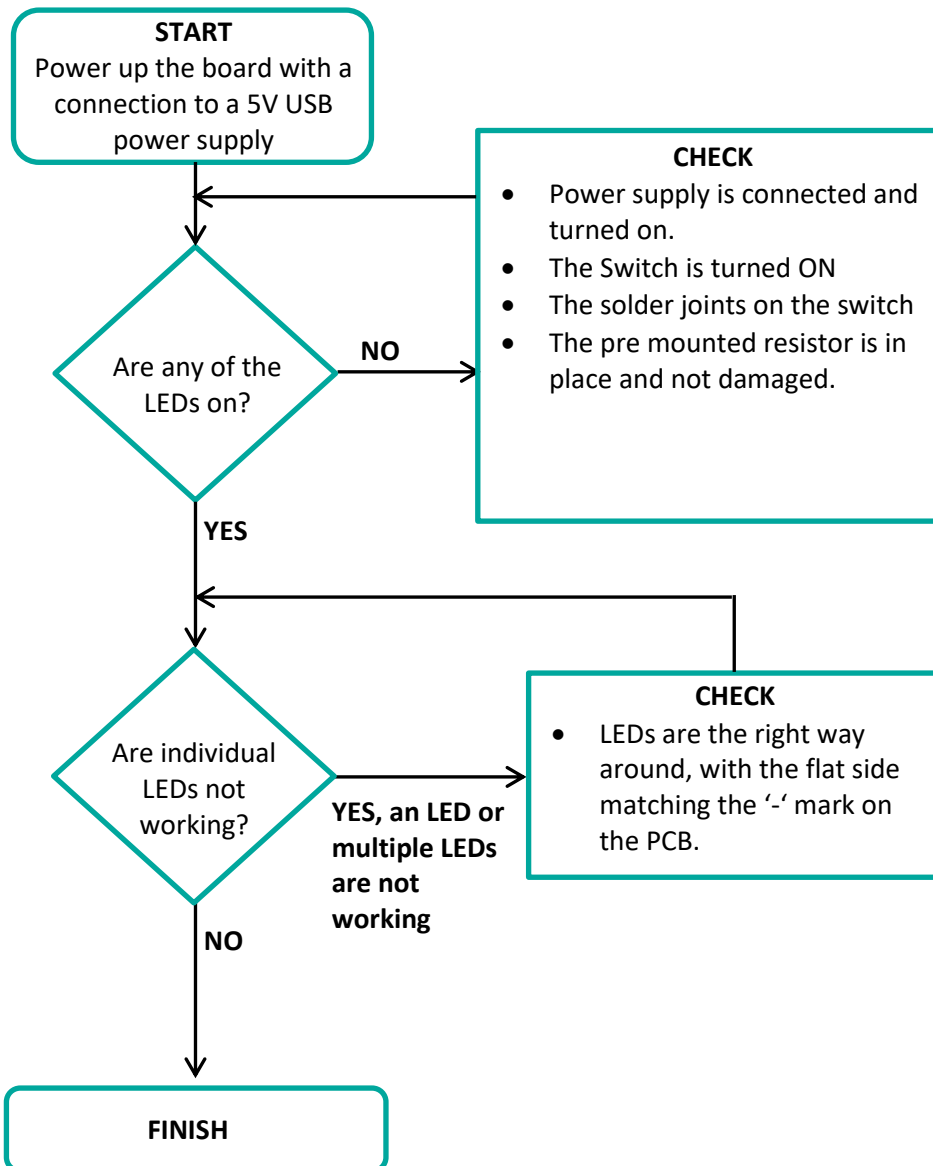

Designing the Enclosure

When you design the enclosure, you will need to consider:

- The size of the PCB (below).
- Where the power cable comes out.
- Where the power switch is
- There is a single 3.2mm hole in the PCB to secure the PCB in the enclosure.

This technical drawing of the built 5V LED Desk Lamp PCB should help you to design your enclosure. The total height of the assembled unit is approximately 9mm.

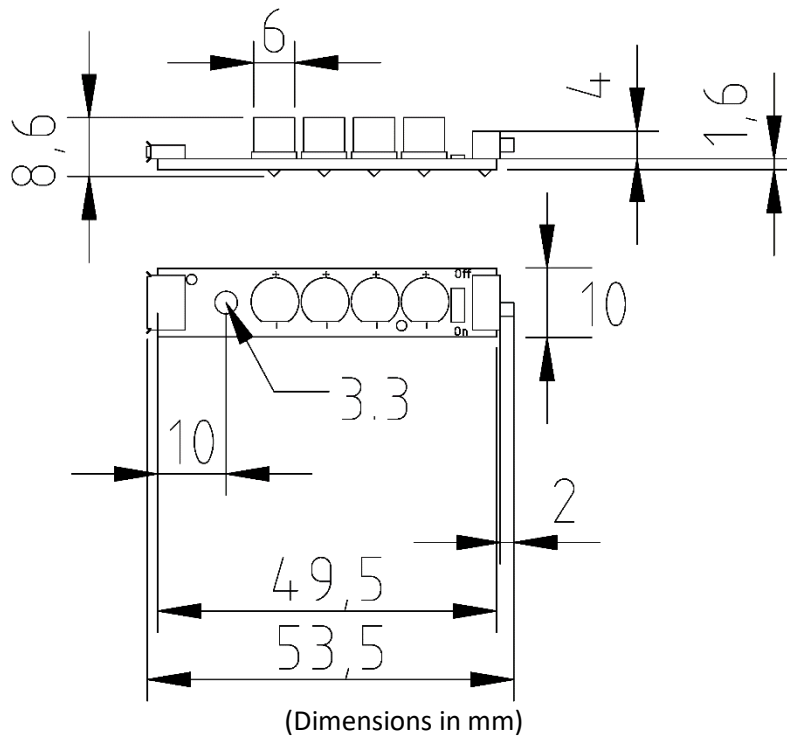

<p>P.C.B SPACER ENCLOSURE 2 X M3 BOLTS</p>	<p>Mounting the PCB to the enclosure</p> <p>The drawing to the left shows how a hex spacer can be used with two bolts to fix the PCB to the enclosure.</p> <p><i>Your PCB has one mounting hole designed to take M3 bolts.</i></p>
--	---



5V LED Strip Kit Essentials

www.kitronik.co.uk/2176



How the 5V LED Strip Works

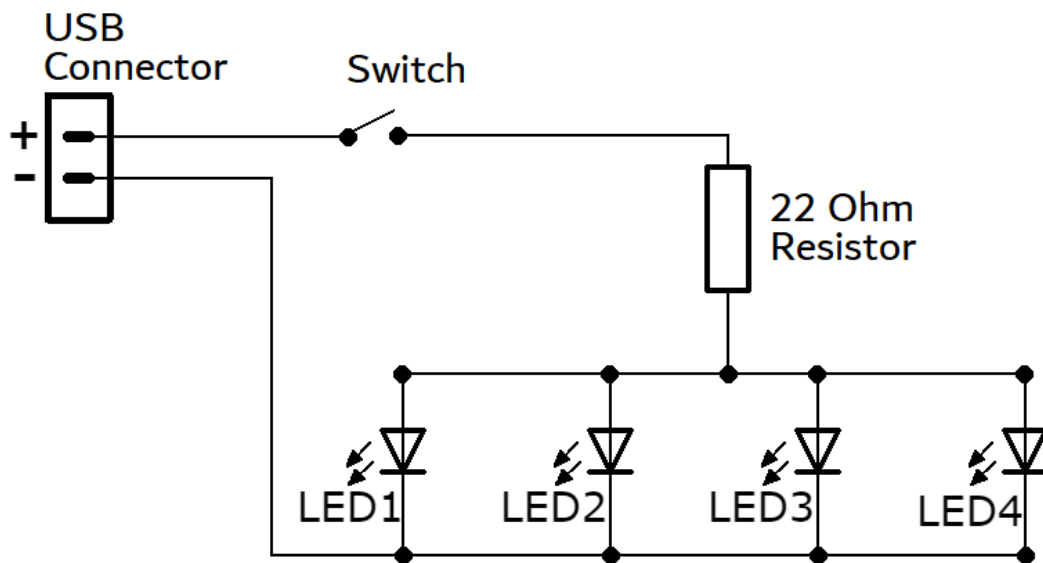

The circuit diagram for the 5V LED Desk Lamp is shown above. It is a very simple circuit. The board contains four LEDs, sharing a current limit resistor.

LEDs can be damaged if too much current goes through them, so a 22 Ohm resistor is used. This allows around 21mA to each LED, or 84mA overall. To save space on the PCB the kit comes with a surface mount resistor already soldered in place.



Online Information

Two sets of information can be downloaded from the product page where the kit can also be reordered from. The 'Essential Information' contains all of the information that you need to get started with the kit and the 'Teaching Resources' contains more information on soldering, components used in the kit, educational schemes of work and so on and also includes the essentials. Download from:

www.kitronik.co.uk/2176

Telephone +44 (0) 845 8380781

Sales email: sales@kitronik.co.uk

Tech Support email: support@kitronik.co.uk

Web: www.kitronik.co.uk



kitronik.co.uk/twitter



kitronik.co.uk/facebook



kitronik.co.uk/youtube



kitronik.co.uk/instagram



Designed & manufactured
in the UK by 



Every effort has been made to ensure that these notes are correct, however Kitronik accept no responsibility for issues arising from errors / omissions in the notes.

© Kitronik Ltd - Any unauthorised copying / duplication of this booklet or part thereof for purposes except for use with Kitronik project kits is not allowed without Kitronik's prior consent.

